

Filters

FT, FB, FI, FW and FH Series



Contents

Tee-type Filters

FT Series



B-182

Bypass Filters

FB Series



B-188

In-line Filters

FI Series



B-194

All-welded In-line Filters

FW Series



B-200

High-capacity Filters

FH Series



B-203

Tee-type Filters

FT Series

Introduction

Tee-Type Filters trap fine particle contaminants in pipelines. With easy-to-replace filter elements, these filters apply to gas and liquid services. Having been ECE R110 certified, they are also suitable for CNG/NGV applications.



Features

- ⦿ Filtration area type: 4 and 8
- ⦿ Union bonnet design to prevent lock nut from falling off and offer added safety
- ⦿ Working pressure up to 6000 psig (414 bar)
- ⦿ Working temperature: -20°F to 900°F (-28°C to 482°C)
- ⦿ Variety of end connections available

Standard Materials of Construction

Item	Component	Body Material	
		316 SS	Brass
		Material Grade/ASTM Specification	
1	Body	F316 SS/A182	C37700/B283
		316 SS/A479	C36000/B16
2	Element	Sintered 316 SS or strainer 316 SS	
3	Gasket	Silver-plated 316 SS	Aluminum/B209
4	Spring	302 SS/A313	
5	Bonnet Nut	316 SS/A479	Brass C36000/B16
6	Backup Ring	Stainless steel	
7	Bonnet	316 SS/A479	Brass C36000/B16

Lubricants: molybdenum disulfide-based and silicone-based

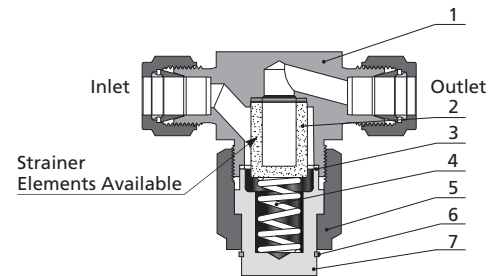

FT Series Sintered Filter Shown

Pressure vs. Temperature

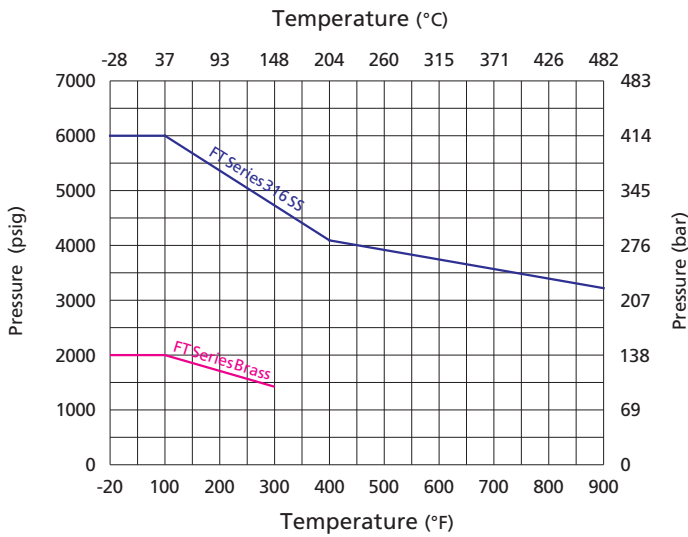

Filter Elements

Sintered

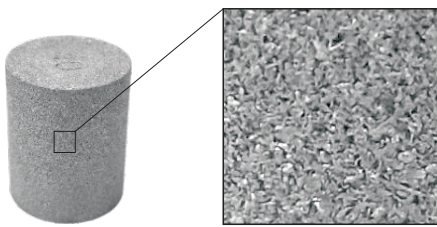

Magnified 10x

- ⦿ 316 SS powder metallurgy
- ⦿ Irregular pores to trap impurity ions with smaller diameters

Strainer

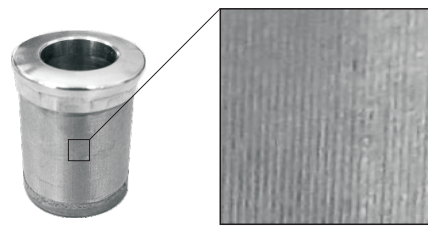

Magnified 10x

- ⦿ 316 SS wire mesh
- ⦿ Uniform mesh pores to trap impurity ions with larger diameters

Nominal Pore Size of Filter Elements

	Nominal Pore Size	Pore Size Range	Element Designator
Sintered	0.5 μm	0.5 to 2 μm	05
	2 μm	1 to 4 μm	2
	7 μm	5 to 10 μm	7
	15 μm	11 to 25 μm	15
	40 μm	35 to 53 μm	40
	60 μm	50 to 75 μm	60
	80 μm	70 to 95 μm	80
Strainer	100 μm	140 mesh	100
	150 μm	100 mesh	150
	250 μm	60 mesh	250
	450 μm	40 mesh	450

Note: Filter elements remove 95% of particles larger than the nominal pore size.

Filtration Area

Filtration Area Type	Filtration Area, in. ² (mm ²)	
	Sintered	Strainer
4	1.30 (830)	1.00 (640)
8	2.00 (1280)	1.70 (1090)

Maximum Differential Pressure of Clean Filter at 70°F (20°C)

Maximum Differential Pressure psig (bar)										
0.5 µm	2 µm	7 µm	15 µm	40 µm	60 µm	80 µm	100 µm	150 µm	250 µm	450 µm
1000 (69.0)										

Flow Data

Filtration Area Type	Element Nominal Pore Size µm	Element Type	Inlet Pressure, psig (bar)			Pressure Drop, psig (bar)		
			5 (0.34)	10 (0.68)	15 (1.0)	10 (0.68)	50 (3.4)	100 (6.8)
			Air Flow, std ft ³ /min (L/min)			Water Flow, U.S. gal/min (L/min)		
4	0.5	Sintered	0.12 (3.4)	0.26 (7.3)	0.48 (13)	0.04 (0.15)	0.17 (0.64)	0.29 (1.0)
	2	Sintered	0.60 (17)	1.4 (39)	2.3 (65)	0.24 (0.90)	0.86 (3.2)	1.3 (4.9)
	7	Sintered	1.4 (39)	2.9 (82)	4.7 (130)	0.40 (1.5)	1.3 (4.9)	2.0 (7.5)
	15	Sintered	1.2 (34)	2.9 (82)	4.7 (130)	0.50 (1.8)	1.3 (4.9)	2.1 (7.9)
	60	Sintered	3.1 (87)	5.9 (160)	8.5 (240)	0.80 (3.0)	2.7 (10)	3.9 (14)
	80	Sintered	4.1 (110)	7.5 (210)	10 (280)	1.1 (4.1)	3.4 (12)	4.9 (18)
	40, 60, 80, 100, 150, 250, 450	Strainer	4.7 (130)	8.8 (250)	12 (340)	1.2 (4.5)	4.2 (15)	5.6 (21)
8	0.5	Sintered	0.36 (10)	0.86 (24)	1.6 (45)	0.09 (0.34)	0.40 (1.5)	0.76 (2.8)
	2	Sintered	1.4 (39)	2.8 (79)	4.0 (110)	0.26 (0.98)	1.1 (4.1)	1.6 (6.0)
	7	Sintered	1.8 (51)	4.2 (119)	6.8 (190)	0.64 (2.4)	2.2 (8.3)	3.5 (13)
	15	Sintered	1.8 (51)	4.9 (130)	7.9 (220)	0.84 (3.1)	2.6 (9.8)	4.1 (15)
	60	Sintered	5.1 (140)	10 (280)	15 (420)	1.5 (5.6)	4.8 (18)	6.7 (25)
	80	Sintered	6.1 (170)	11 (310)	16 (450)	1.7 (6.4)	5.5 (20)	7.6 (28)
	40, 60, 80, 100, 150, 250, 450	Strainer	7.2 (200)	14 (390)	20 (560)	2.4 (9.0)	7.2 (27)	10 (37)

Note: Outlet is discharged to the atmosphere.

Dimensions and Ordering Information

Dimensions, in inches (millimeters), are for reference only.

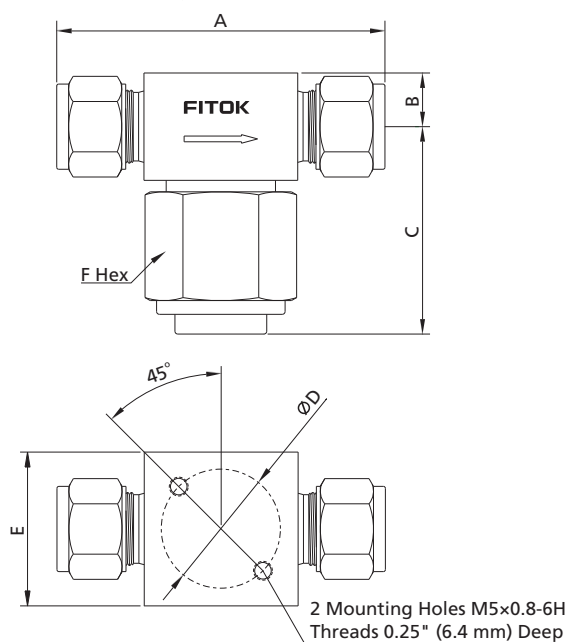

Basic Ordering Number	Connection Type and Size		Filtration Area Type	Dimensions, in. (mm)					
	Inlet	Outlet		A	B	C	ØD	E	F
FT□□-FL2-	1/8" Tube Fitting	1/8" Tube Fitting	4	2.27 (57.7)	0.38 (9.7)	1.49 (37.8)	1.00 (25.4)	1.00 (25.4)	1 (25.4)
FT□□-FL4-	1/4" Tube Fitting	1/4" Tube Fitting	4	2.47 (62.7)					
FT□□-FL6-	3/8" Tube Fitting	3/8" Tube Fitting	8	2.84 (72.1)	0.46 (11.7)	1.74 (44.2)	1.13 (28.7)	1.13 (28.7)	1 1/8 (28.6)
FT□□-FL8-	1/2" Tube Fitting	1/2" Tube Fitting	8	3.04 (77.2)					
FT□□-ML6-	6 mm Tube Fitting	6 mm Tube Fitting	4	2.46 (62.5)	0.38 (9.7)	1.49 (37.8)	1.00 (25.4)	1.00 (25.4)	1 (25.4)
FT□□-ML8-	8 mm Tube Fitting	8 mm Tube Fitting	8	2.84 (72.1)					
FT□□-ML10-	10 mm Tube Fitting	10 mm Tube Fitting	8	2.86 (72.6)	0.46 (11.7)	1.74 (44.2)	1.13 (28.7)	1.13 (28.7)	1 1/8 (28.6)
FT□□-ML12-	12 mm Tube Fitting	12 mm Tube Fitting	8	3.04 (77.2)					
FT□□-TS4-	1/4" Tube Socket Weld	1/4" Tube Socket Weld	4	1.68 (42.7)	0.38 (9.7)	1.49 (37.8)	1.00 (25.4)	1.00 (25.4)	1 (25.4)
FT□□-TS6-	3/8" Tube Socket Weld	3/8" Tube Socket Weld	4						
FT□□-TB4-	1/4" x 0.065" Tube Butt Weld	1/4" x 0.065" Tube Butt Weld	4						
FT□□-TB6-	3/8" x 0.095" Tube Butt Weld	3/8" x 0.095" Tube Butt Weld	4						
FT□□-FNS2-	1/8 Female NPT	1/8 Female NPT	4	2.00 (50.8)	0.38 (9.7)	1.49 (37.8)	1.00 (25.4)	1.00 (25.4)	1 (25.4)
FT□□-FNS4-	1/4 Female NPT	1/4 Female NPT	4	2.13 (54.1)					
FT□□-NS4-	1/4 Male NPT	1/4 Male NPT	4						
FT□□-NS6-	3/8 Male NPT	3/8 Male NPT	8	2.38 (60.5)	0.46 (11.7)	1.74 (44.2)	1.13 (28.7)	1.13 (28.7)	1 1/8 (28.6)
FT□□-NS8-	1/2 Male NPT	1/2 Male NPT	8	2.75 (69.9)					
FT□□-FR4-	1/4 Male FR	1/4 Male FR	4	2.30 (58.4)	0.38 (9.7)	1.49 (37.8)	1.00 (25.4)	1.00 (25.4)	1 (25.4)
FT□□-FR8-	1/2 Male FR	1/2 Male FR	8	2.55 (64.8)	0.46 (11.7)	1.74 (44.2)	1.13 (28.7)	1.13 (28.7)	1 1/8 (28.6)

1. Mounting holes not available with 1/4 female NPT end connections
2. FR means metal gasket seal fittings.
3. Sizes and types listed are standard. Other sizes and types are available upon request.
4. Dimensions are shown with FITOK nuts finger-tightened. All dimensions are for reference only and are subject to change. For dimensions not shown above, please contact FITOK Group or our authorized distributors.

Filters Ordering Number Description

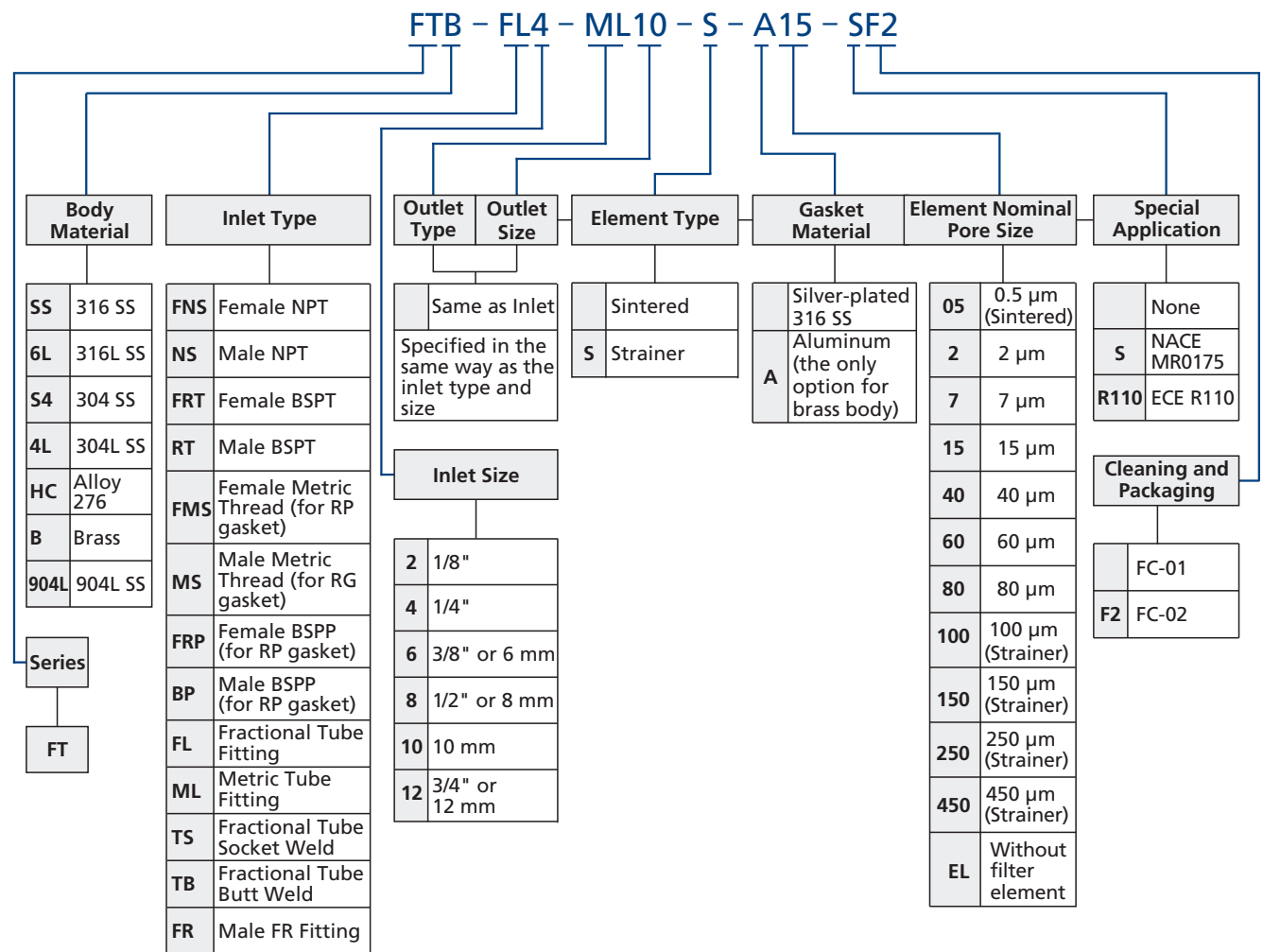

Note: "Ordering Number Description" is a reference to understand the combination rules of FITOK product part number. Not all combinations are available.

1. Cleaning and Packaging:

FC-01: Standard cleaning and packaging for basic industrial procedures.

FC-02: Special cleaning and packaging for wetted system components to ensure compliance requirement as stated in ASTM G93 Level C.

2. Standard thread pitch for metric threads are as follows:

M10 and below: 1 mm

M12 to M24: 1.5 mm

M27 and above: 2 mm

Standard thread pitch should be ignored in the ordering number, others should be specified.

CNG/NGV Application

FT Series Filters with ECE R110 Type Approval (Class 0) are available.

Rated temperatures: -40°F to 248°F (-40°C to 120°C)

Rated pressure within the temperature range: 3370 psig (260 bar)

To order, add the suffix -R110 to the standard FT series filter ordering number.

Example: FTSS-FL4-15-R110

Elements Ordering Number Description

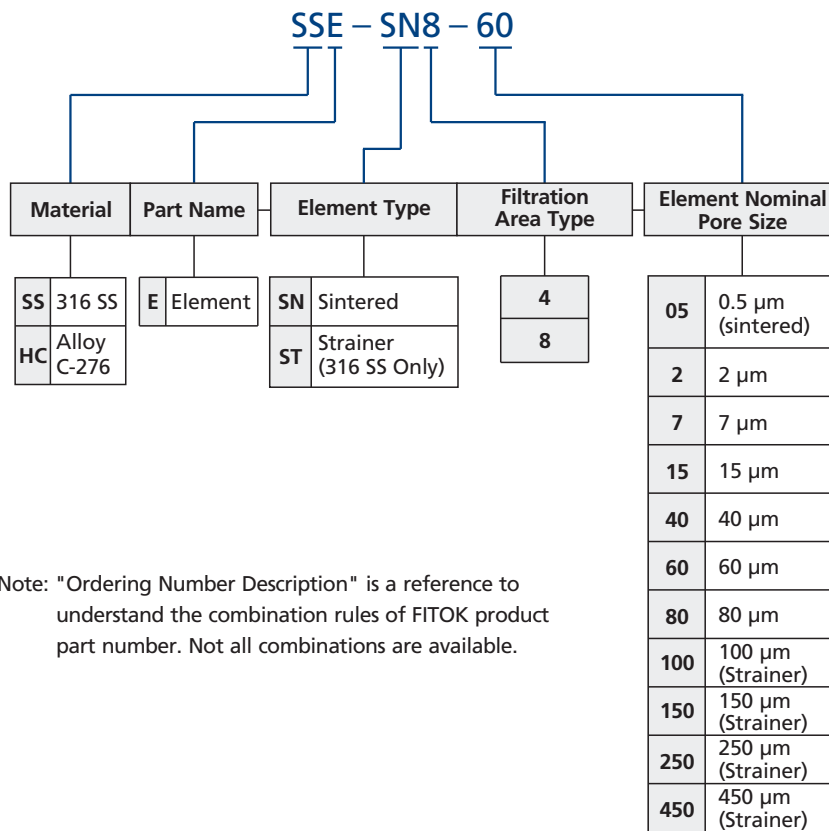

Bypass Filters

FB Series

Introduction

Bypass Filters can be used for medium sampling and element cleaning. Filter elements are available in multiple types of filtration accuracy and are easy to replace, making them suitable for use in gas and fluid service.



Features

- ⦿ Filtration area type: 4 and 8
- ⦿ Union bonnet design to prevent lock nut from falling off and offer added safety
- ⦿ Working pressure up to 6000 psig (414 bar)
- ⦿ Working temperature: -20°F to 900°F (-28°C to 482°C)
- ⦿ Variety of end connections available

Standard Materials of Construction

Item	Component	Body Material	
		316 SS	Brass
Material Grade/ASTM Specification			
1	Body	F316 SS/A182	C37700/B283
		316 SS/A479	C36000/B16
2	Element	Sintered 316 SS or strainer 316 SS	
3	Gasket	Silver-plated 316 SS	Aluminum/B209
4	Spring	302 SS/A313	
5	Bonnet Nut	316 SS/A479	Brass C36000/B16
6	Backup Ring	Stainless steel	
7	Bonnet	316 SS/A479	Brass C36000/B16

Lubricants: molybdenum disulfide-based and silicone-based

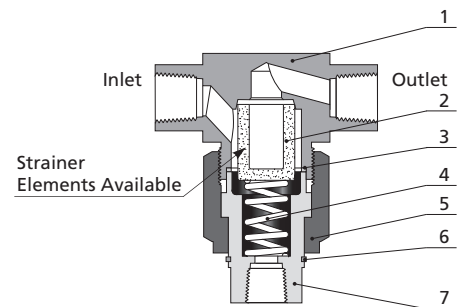

FB Series Sintered Filter Shown

Pressure vs. Temperature

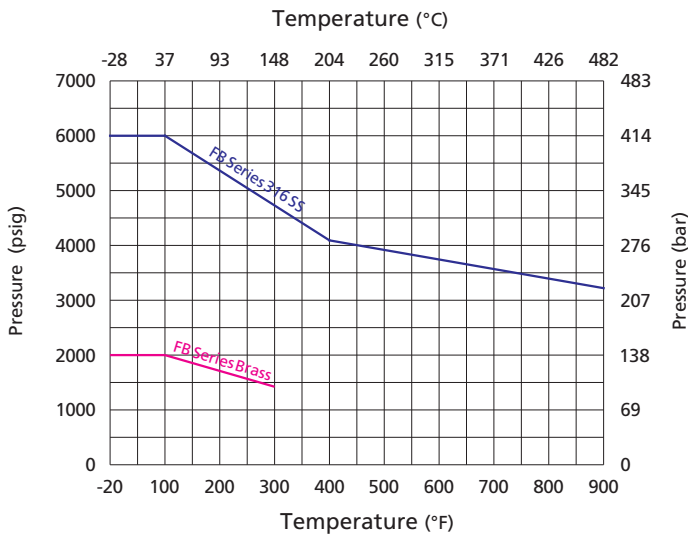

Filter Elements

Sintered

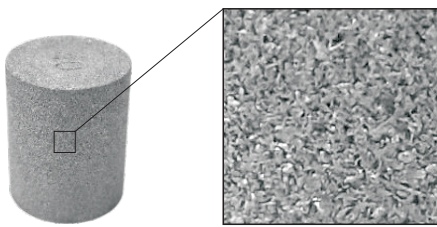

Magnified 10x

- ⦿ 316 SS powder metallurgy
- ⦿ Irregular pores to trap impurity ions with smaller diameters

Strainer

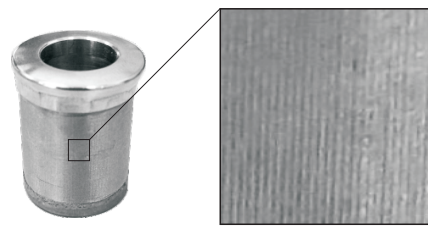

Magnified 10x

- ⦿ 316 SS wire mesh
- ⦿ Uniform mesh pores to trap impurity ions with larger diameters

Nominal Pore Size of Filter Elements

	Nominal Pore Size	Pore Size Range	Element Designator
Sintered	0.5 μm	0.5 to 2 μm	05
	2 μm	1 to 4 μm	2
	7 μm	5 to 10 μm	7
	15 μm	11 to 25 μm	15
	40 μm	35 to 53 μm	40
	60 μm	50 to 75 μm	60
	80 μm	70 to 95 μm	80
Strainer	100 μm	140 mesh	100
	150 μm	100 mesh	150
	250 μm	60 mesh	250
	450 μm	40 mesh	450

Note: Filter elements remove 95% of particles larger than the nominal pore size.

Filtration Area

Filtration Area Type	Filtration Area, in. ² (mm ²)	
	Sintered	Strainer
4	1.30 (830)	1.00 (640)
8	2.00 (1280)	1.70 (1090)

Maximum Differential Pressure of Clean Filter at 70°F (20°C)

Maximum Differential Pressure psig (bar)										
0.5 µm	2 µm	7 µm	15 µm	40 µm	60 µm	80 µm	100 µm	150 µm	250 µm	450 µm
1000 (69.0)										

Flow Data

Filtration Area Type	Element Nominal Pore Size µm	Element Type	Inlet Pressure, psig (bar)			Pressure Drop, psig (bar)		
			5 (0.34)	10 (0.68)	15 (1.0)	10 (0.68)	50 (3.4)	100 (6.8)
			Air Flow, std ft ³ /min (L/min)			Water Flow, U.S. gal/min (L/min)		
4	0.5	Sintered	0.12 (3.4)	0.26 (7.3)	0.48 (13)	0.04 (0.15)	0.17 (0.64)	0.29 (1.0)
	2	Sintered	0.60 (17)	1.4 (39)	2.3 (65)	0.24 (0.90)	0.86 (3.2)	1.3 (4.9)
	7	Sintered	1.4 (39)	2.9 (82)	4.7 (130)	0.40 (1.5)	1.3 (4.9)	2.0 (7.5)
	15	Sintered	1.2 (34)	2.9 (82)	4.7 (130)	0.50 (1.8)	1.3 (4.9)	2.1 (7.9)
	60	Sintered	3.1 (87)	5.9 (160)	8.5 (240)	0.80 (3.0)	2.7 (10)	3.9 (14)
	80	Sintered	4.1 (110)	7.5 (210)	10 (280)	1.1 (4.1)	3.4 (12)	4.9 (18)
	40, 60, 80, 100, 150, 250, 450	Strainer	4.7 (130)	8.8 (250)	12 (340)	1.2 (4.5)	4.2 (15)	5.6 (21)
8	0.5	Sintered	0.36 (10)	0.86 (24)	1.6 (45)	0.09 (0.34)	0.40 (1.5)	0.76 (2.8)
	2	Sintered	1.4 (39)	2.8 (79)	4.0 (110)	0.26 (0.98)	1.1 (4.1)	1.6 (6.0)
	7	Sintered	1.8 (51)	4.2 (119)	6.8 (190)	0.64 (2.4)	2.2 (8.3)	3.5 (13)
	15	Sintered	1.8 (51)	4.9 (130)	7.9 (220)	0.84 (3.1)	2.6 (9.8)	4.1 (15)
	60	Sintered	5.1 (140)	10 (280)	15 (420)	1.5 (5.6)	4.8 (18)	6.7 (25)
	80	Sintered	6.1 (170)	11 (310)	16 (450)	1.7 (6.4)	5.5 (20)	7.6 (28)
	40, 60, 80, 100, 150, 250, 450	Strainer	7.2 (200)	14 (390)	20 (560)	2.4 (9.0)	7.2 (27)	10 (37)

Note: Outlet is discharged to the atmosphere.

Dimensions and Ordering Information

Dimensions, in inches (millimeters), are for reference only.

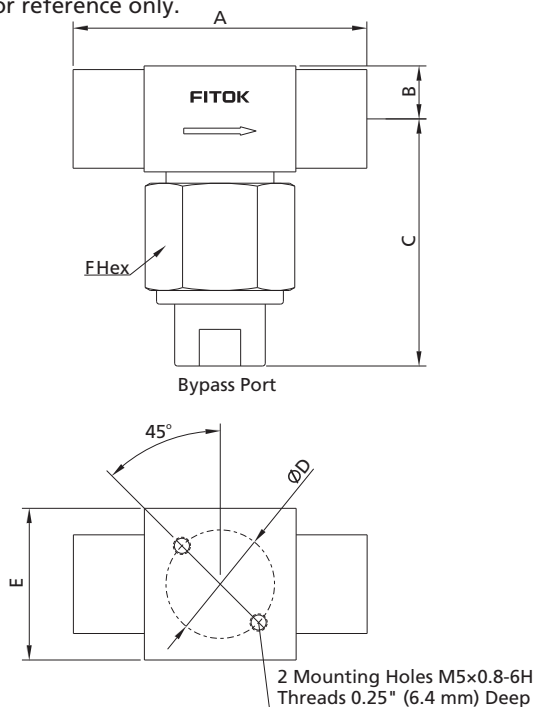

Basic Ordering Number	Connection Type and Size		Filtration Area Type	Dimensions, in. (mm)						
	Inlet	Outlet		A	B	C	ØD	E	F	Bypass Port
FB□□-FL2-	1/8" Tube Fitting	1/8" Tube Fitting	4	2.27 (57.7)	0.38 (9.7)	1.98 (50.2)	1.00 (25.4)	1.00 (25.4)	1 (25.4)	FL2
FB□□-FL4-	1/4" Tube Fitting	1/4" Tube Fitting	4	2.47 (62.7)		2.44 (61.9)				FL4
FB□□-FL6-	3/8" Tube Fitting	3/8" Tube Fitting	8	2.84 (72.1)	0.46 (11.7)	2.74 (69.1)	1.13 (28.7)	1.13 (28.7)	1 1/8 (28.6)	FL6
FB□□-FL8-	1/2" Tube Fitting	1/2" Tube Fitting	8	3.04 (77.2)		2.96 (74.2)				FL8
FB□□-ML6-	6 mm Tube Fitting	6 mm Tube Fitting	4	2.46 (62.5)	0.38 (9.7)	2.44 (61.9)	1.00 (25.4)	1.00 (25.4)	1 (25.4)	FL4
FB□□-ML8-	8 mm Tube Fitting	8 mm Tube Fitting	8	2.84 (72.1)	0.46 (11.7)	2.74 (69.1)	1.13 (28.7)	1.13 (28.7)	1 1/8 (28.6)	FL6
FB□□-ML10-	10 mm Tube Fitting	10 mm Tube Fitting	8	2.86 (72.6)		2.96 (74.2)				FL8
FB□□-ML12-	12 mm Tube Fitting	12 mm Tube Fitting	8	3.04 (77.2)						
FB□□-TS4-	1/4" Tube Socket Weld	1/4" Tube Socket Weld	4	1.68 (42.7)	0.38 (9.7)	1.83 (56.4)	1.00 (25.4)	1.00 (25.4)	1 (25.4)	TS4
FB□□-TS6-	3/8" Tube Socket Weld	3/8" Tube Socket Weld	4							
FB□□-TB4-	1/4" x0.065" Tube Butt Weld	1/4" x0.065" Tube Butt Weld	4							
FB□□-TB4-	3/8" x0.095" Tube Butt Weld	3/8" x0.095" Tube Butt Weld	4							
FB□□-FNS2-	1/8 Female NPT	1/8 Female NPT	4	2.00 (50.8)	0.38 (9.7)	1.71 (43.4)	1.00 (25.4)	1.00 (25.4)	1 (25.4)	FNS2
FB□□-FNS4-	1/4 Female NPT	1/4 Female NPT	4	2.13 (54.1)						
FB□□-NS4-	1/4 Male NPT	1/4 Male NPT	4							
FB□□-NS6-	3/8 Male NPT	3/8 Male NPT	8	2.38 (60.5)	0.46 (11.7)	2.00 (50.8)	1.13 (28.7)	1.13 (28.7)	1 1/8 (28.6)	
FB□□-NS8-	1/2 Male NPT	1/2 Male NPT	8	2.75 (69.9)						
FB□□-FR4-	1/4 Male FR	1/4 Male FR	4	2.38 (60.5)	0.38 (9.7)	2.44 (61.9)	1.00 (25.4)	1.00 (25.4)	1 (25.4)	FL4
FB□□-FR8-	1/2 Male FR	1/2 Male FR	8	2.75 (69.9)	0.46 (11.7)	2.96 (74.2)	1.13 (28.7)	1.13 (28.7)	1 1/8 (28.6)	FL8

1. Mounting holes not available with 1/4 female NPT end connections.
2. FR means metal gasket seal fittings.
3. Sizes and types listed are standard. Other sizes and types are available upon request.
4. Dimensions are shown with FITOK nuts finger-tightened. All dimensions are for reference only and are subject to change. For dimensions not shown above, please contact FITOK Group or our authorized distributors.

Filters Ordering Number Description

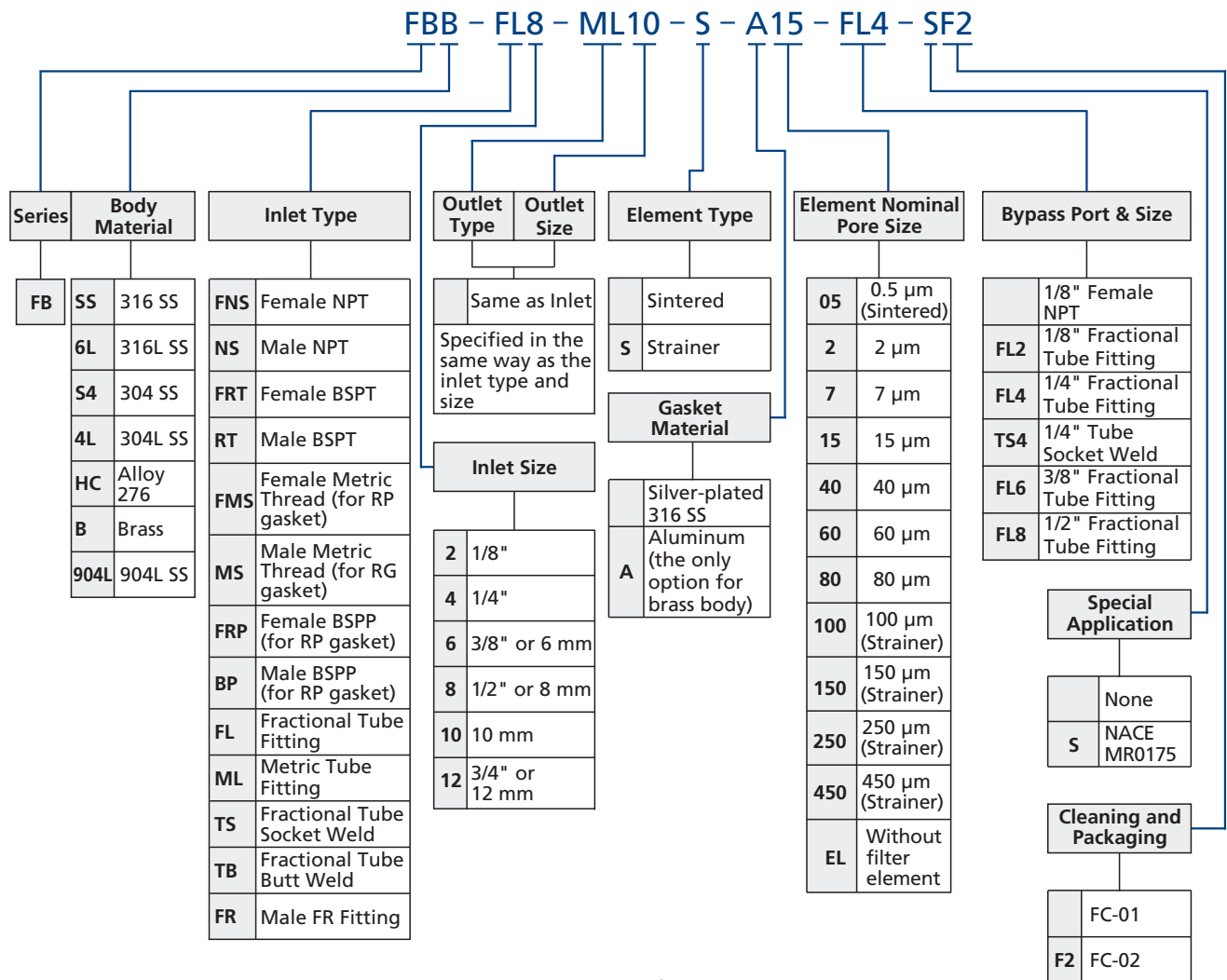

Note: "Ordering Number Description" is a reference to understand the combination rules of FITOK product part number. Not all combinations are available.

1. Cleaning and Packaging:

- FC-01: Standard cleaning and packaging for basic industrial procedures.
- FC-02: Special cleaning and packaging for wetted system components to ensure compliance requirement as stated in ASTM G93 Level C.

2. Standard thread pitch for metric threads are as follows:

- M10 and below: 1 mm
- M12 to M24: 1.5 mm
- M27 and above: 2 mm

Standard thread pitch should be ignored in the ordering number, others should be specified.

Elements Ordering Number Description

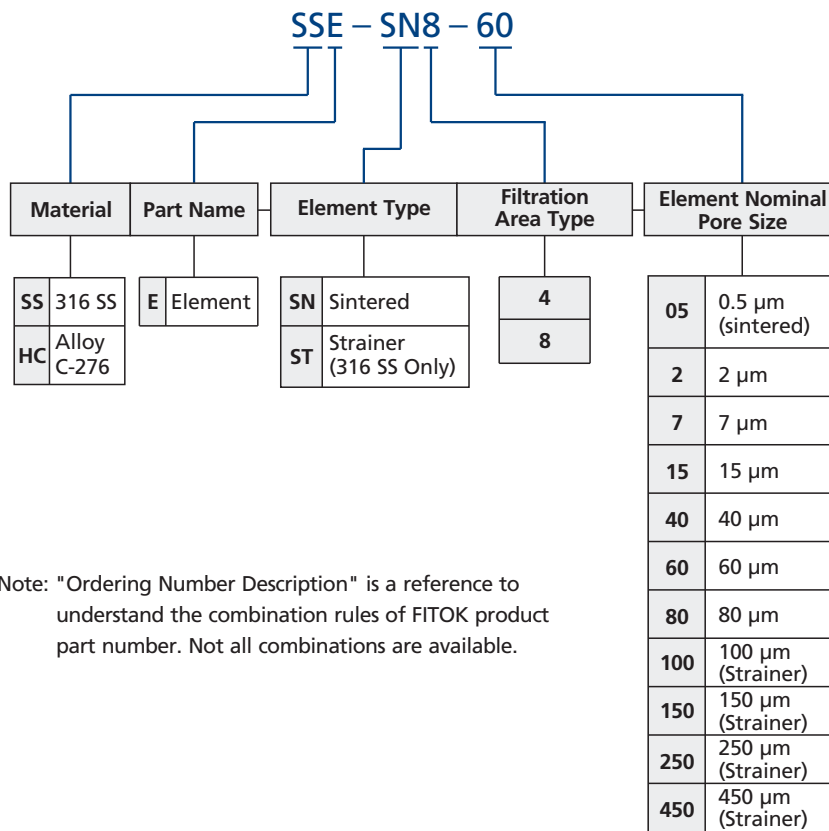

In-line Filters

FI Series



Introduction

In-line Filters are compact-designed to trap particle contaminants in gas or liquid service in limited space. Filter elements are available in multiple types of filtration accuracy to meet filtration needs of various pipelines.

Features

- ⦿ Filtration area type: 2, 4 and 8
- ⦿ Compact and space-saving design
- ⦿ Working pressure up to 3000 psig (207 bar)
- ⦿ Working temperature: -20°F to 900°F (-28°C to 482°C)
- ⦿ Variety of end connections available

Standard Materials of Construction

Item	Component	Body Material	
		316 SS	Brass
		Material Grade/ASTM Specification	
1	Body	F316 SS/A182	C37700/B283
		316 SS/A479	C36000/B16
2	Element	Sintered 316 SS or strainer 316 SS	
3	Gasket	Silver-plated 316 SS	Aluminum/B209
4	Spring	302 SS/A313	
5	Bonnet Nut	316 SS/A479	Brass C36000/B16
6	Backup Ring	Stainless steel	
7	Bonnet	316 SS/A479	Brass C36000/B16

Lubricants: molybdenum disulfide-based and silicone-based

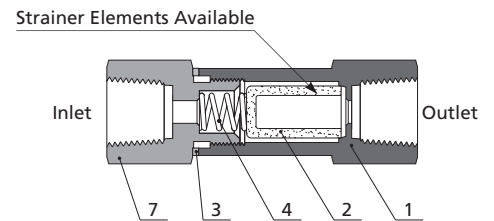

FI Series Sintered Filter Shown

Pressure vs. Temperature

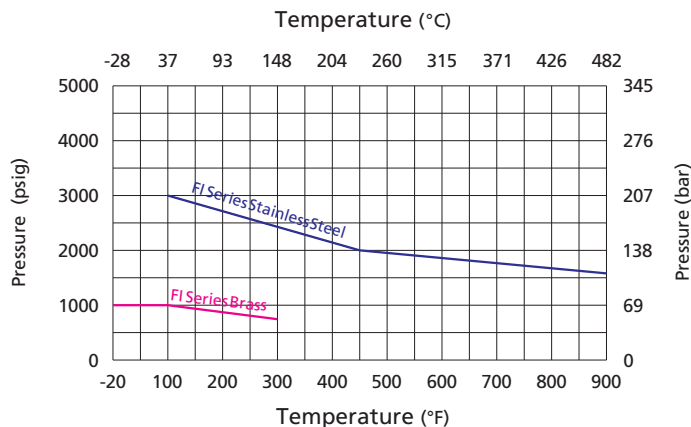

Filter Elements

Sintered

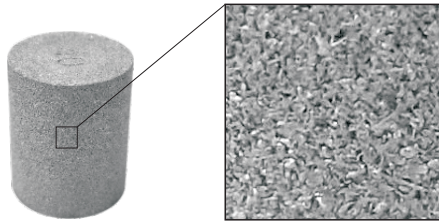

Magnified 10x

Strainer

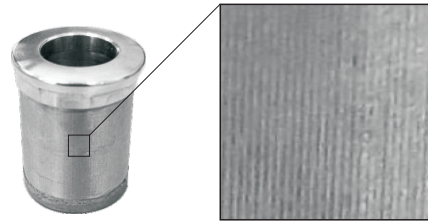

Magnified 10x

- ⦿ 316 SS powder metallurgy
- ⦿ Irregular pores to trap impurity ions with smaller diameters

- ⦿ 316 SS wire mesh
- ⦿ Uniform mesh pores to trap impurity ions with larger diameters

Nominal Pore Size of Filter Elements

	Nominal Pore Size	Pore Size Range	Element Designator
Sintered	0.5 μm	0.5 to 2 μm	05
	2 μm	1 to 4 μm	2
	7 μm	5 to 10 μm	7
	15 μm	11 to 25 μm	15
	40 μm	35 to 53 μm	40
	60 μm	50 to 75 μm	60
	80 μm	70 to 95 μm	80
Strainer	100 μm	140 mesh	100
	150 μm	100 mesh	150
	250 μm	60 mesh	250
	450 μm	40 mesh	450

Note: Filter elements remove 95% of particles larger than the nominal pore size.

Filtration Area

Filtration Area Type	Filtration Area, in. ² (mm ²)	
	Sintered	Strainer
2	0.55 (350)	—
4	1.30 (830)	1.00 (640)
8	2.00 (1280)	1.70 (1090)

Note: No strainer element option for FI series filtration area type.

Maximum Differential Pressure of Clean Filter at 70°F (20°C)

Maximum Differential Pressure psig (bar)										
0.5 μm	2 μm	7 μm	15 μm	40 μm	60 μm	80 μm	100 μm	150 μm	250 μm	450 μm
1000 (69.0)										

Flow Data

Filtration Area Type	Element Nominal Pore Size μm	Element Type	Inlet Pressure, psig (bar)			Pressure Drop, psig (bar)		
			5 (0.34)	10 (0.68)	15 (1.0)	10 (0.68)	50 (3.4)	100 (6.8)
			Air Flow, std ft ³ /min (L/min)			Water Flow, U.S. gal/min (L/min)		
2	0.5	Sintered	0.04 (1.1)	0.06 (1.7)	0.12 (3.4)	0.01 (0.03)	0.04 (0.15)	0.12 (0.45)
	2	Sintered	0.20 (5.6)	0.40 (11)	0.60 (17)	0.08 (0.30)	0.24 (0.91)	0.40 (1.5)
	7	Sintered	0.50 (14)	0.90 (25)	1.2 (34)	0.10 (0.37)	0.30 (1.1)	0.48 (1.8)
	15	Sintered	0.80 (22)	1.3 (36)	1.5 (42)	0.12 (0.45)	0.36 (1.3)	0.58 (2.1)
	60	Sintered	1.7 (48)	2.2 (62)	2.4 (68)	0.15 (0.56)	0.50 (1.8)	0.70 (2.6)
	80	Sintered	1.8 (51)	2.2 (62)	2.6 (73)	0.20 (0.75)	0.50 (1.8)	0.60 (2.2)
4	0.5	Sintered	0.12 (3.4)	0.26 (7.3)	0.48 (13)	0.04 (0.15)	0.17 (0.64)	0.29 (1.0)
	2	Sintered	0.60 (17)	1.4 (39)	2.3 (65)	0.24 (0.90)	0.86 (3.2)	1.3 (4.9)
	7	Sintered	1.4 (39)	2.9 (82)	4.7 (130)	0.40 (1.5)	1.3 (4.9)	2.0 (7.5)
	15	Sintered	1.2 (34)	2.9 (82)	4.7 (130)	0.50 (1.8)	1.3 (4.9)	2.1 (7.9)
	60	Sintered	3.1 (87)	5.9 (160)	8.5 (240)	0.90 (3.4)	3.3 (12)	4.6 (17)
	80	Sintered	4.1 (110)	7.5 (210)	10 (280)	1.2 (4.5)	4.2 (15)	6.1 (23)
	40, 60, 80, 100, 150, 250, 450	Strainer	4.7 (130)	8.8 (250)	12 (340)	1.7 (6.4)	5.6 (21)	7.8 (29)
8	0.5	Sintered	0.36 (10)	0.86 (24)	1.6 (45)	0.09 (0.34)	0.40 (1.5)	0.76 (2.8)
	2	Sintered	1.4 (39)	2.8 (79)	4.0 (110)	0.26 (0.98)	1.1 (4.1)	1.6 (6.0)
	7	Sintered	1.8 (51)	4.2 (119)	6.8 (190)	0.64 (2.4)	2.2 (8.3)	3.5 (13)
	15	Sintered	1.8 (51)	4.9 (130)	7.9 (220)	0.84 (3.1)	2.6 (9.8)	4.1 (15)
	60	Sintered	5.1 (140)	10 (280)	15 (420)	2.0 (7.5)	6.7 (25)	10 (37)
	80	Sintered	6.1 (170)	11 (310)	16 (450)	2.3 (8.7)	7.6 (28)	11 (41)
	40, 60, 80, 100, 150, 250, 450	Strainer	7.2 (200)	14 (390)	20 (560)	4.8 (18)	15 (56)	19 (71)

Note: Outlet is discharged to the atmosphere.

Dimensions and Ordering Information

Dimensions, in inches (millimeters), are for reference only.

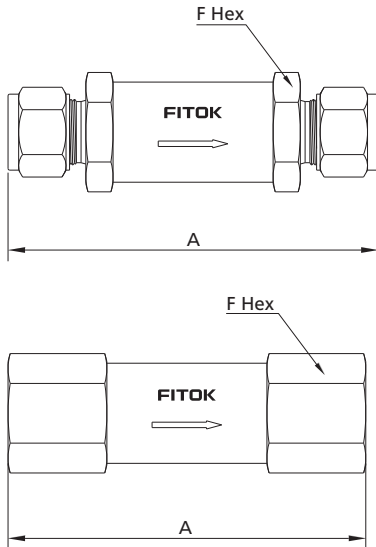

Basic Ordering Number	Connection Type and Size		Filtration Area Type	Dimensions in. (mm)	
	Inlet	Outlet		A	F
FI□□-FL2-	1/8" Tube Fitting	1/8" Tube Fitting	2	2.35 (59.7)	9/16 (14.3)
FI□□-FL4-	1/4" Tube Fitting	1/4" Tube Fitting	4	2.95 (74.9)	3/4 (19.1)
FI□□-FL6-	3/8" Tube Fitting	3/8" Tube Fitting	8	3.21 (81.5)	1 (25.4)
FI□□-FL8-	1/2" Tube Fitting	1/2" Tube Fitting	8	3.49 (88.6)	
FI□□-ML3-	3 mm Tube Fitting	3 mm Tube Fitting	2	2.38 (60.5)	9/16 (14.3)
FI□□-ML6-	6 mm Tube Fitting	6 mm Tube Fitting	4	2.96 (75.2)	3/4 (19.1)
FI□□-FNS2-	1/8 Female NPT	1/8 Female NPT	2	2.16 (54.9)	9/16 (14.3)
FI□□-FNS4-	1/4 Female NPT	1/4 Female NPT	4	2.87 (72.9)	3/4 (19.1)
FI□□-NS2-	1/8 Male NPT	1/8 Male NPT	2	1.88 (47.7)	9/16 (14.3)
FI□□-NS4-	1/4 Male NPT	1/4 Male NPT	4	2.69 (68.3)	3/4 (19.1)
FI□□-FR2-	1/8 Male FR	1/8 Male FR	2	2.79 (70.8)	
FI□□-FR4-	1/4 Male FR	1/4 Male FR	4		
FI□□-FRT2-	1/8 Female BSPT	1/8 Female BSPT	2	2.16 (54.9)	9/16 (14.3)
FI□□-FRT4-	1/4 Female BSPT	1/4 Female BSPT	4	2.87 (72.9)	3/4 (19.1)
FI□□-RT2-	1/8 Male BSPT	1/8 Male BSPT	2	1.88 (47.7)	9/16 (14.3)
FI□□-RT4-	1/4 Male BSPT	1/4 Male BSPT	4	2.69 (68.3)	3/4 (19.1)

1. FR means metal gasket seal fittings.
2. Sizes and types listed are standard. Other sizes and types are available upon request.
3. Dimensions are shown with FITOK nuts finger-tightened. All dimensions are for reference only and are subject to change. For dimensions not shown above, please contact FITOK Group or our authorized distributors.

Filters Ordering Number Description

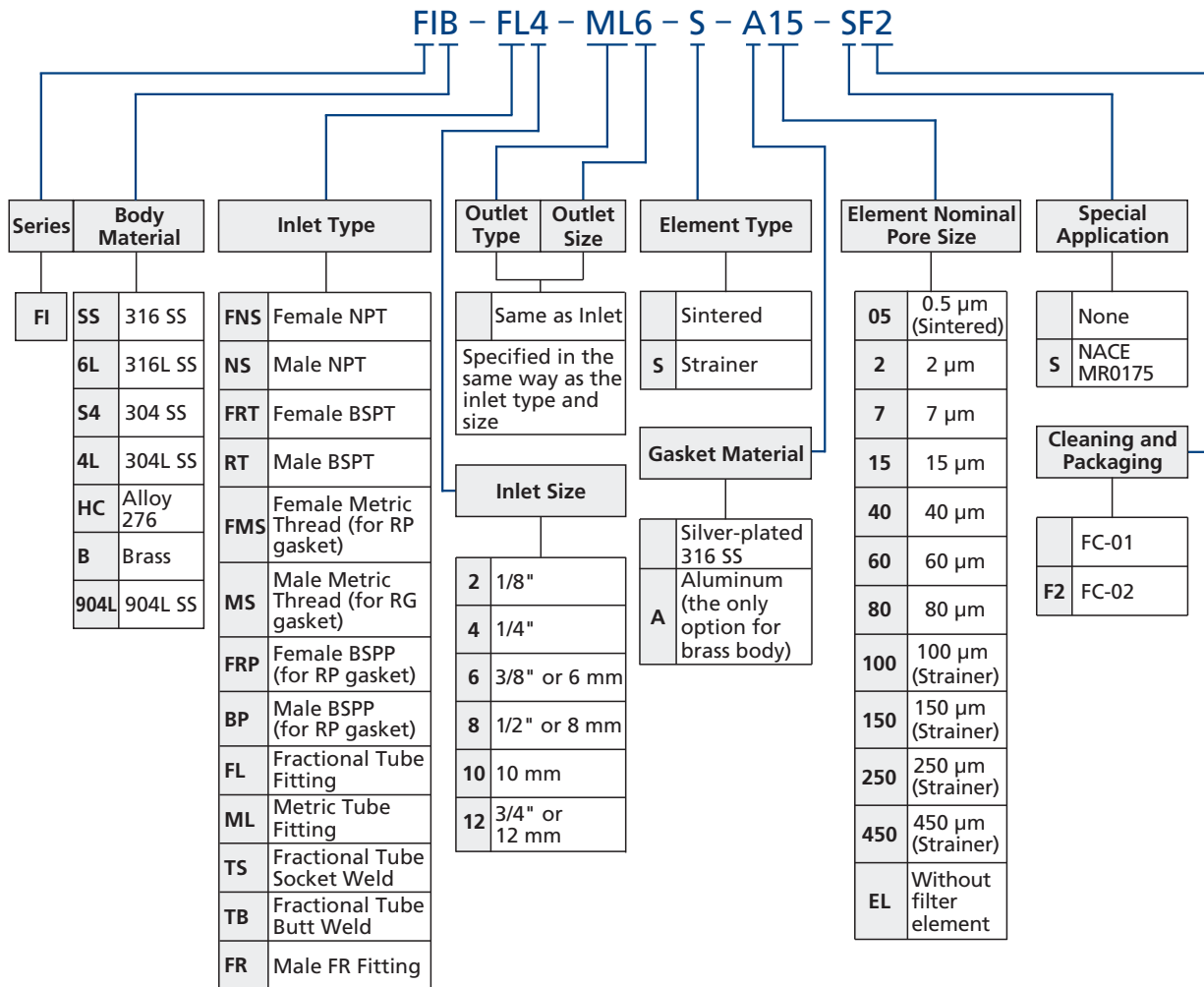

Note: "Ordering Number Description" is a reference to understand the combination rules of FITOK product part number. Not all combinations are available.

- Cleaning and Packaging:
 - FC-01: Standard cleaning and packaging for basic industrial procedures.
 - FC-02: Special cleaning and packaging for wetted system components to ensure compliance requirement as stated in ASTM G93 Level C.
- Standard thread pitch for metric threads are as follows:
 - M10 and below: 1 mm
 - M12 to M24: 1.5 mm
 - M27 and above: 2 mm
 Standard thread pitch should be ignored in the ordering number, others should be specified.

Elements Ordering Number Description

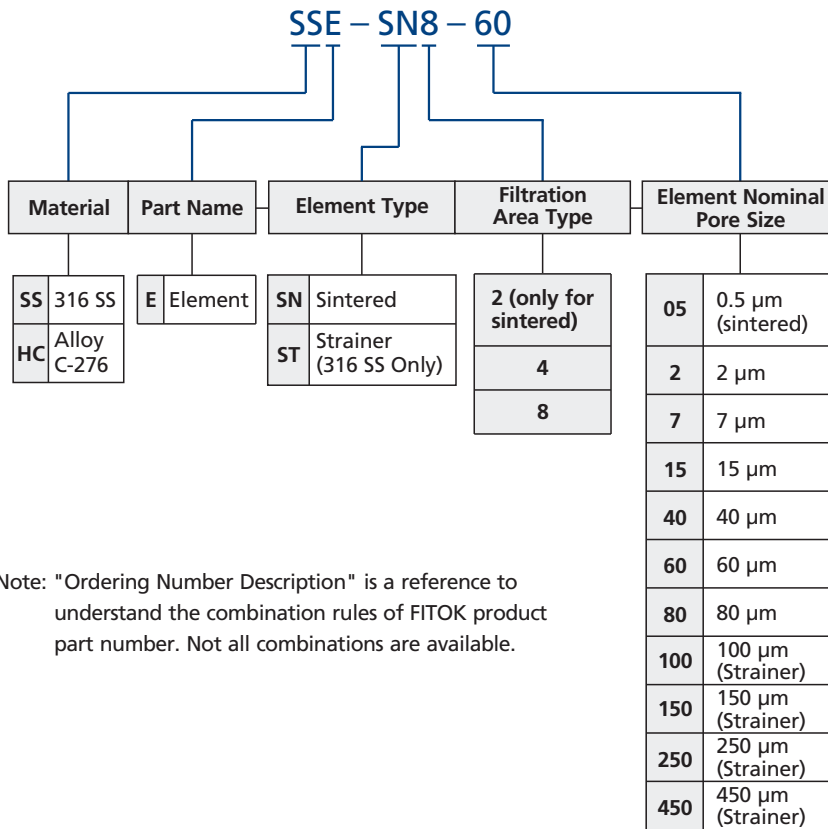

Note: "Ordering Number Description" is a reference to understand the combination rules of FITOK product part number. Not all combinations are available.

All-welded In-line Filters

FW Series

Introduction

All-welded In-line Filters are compact-designed to trap particle contaminants in limited space. Body-to-element weld prevents bypass flow. Filter elements can be easily cleaned by back-flushing.



Features

- ⦿ Full-penetration weld between body and filter element
- ⦿ Working pressure up to 6000 psig (414 bar)
- ⦿ Working temperature: -20°F to 900°F (-28°C to 482°C)
- ⦿ Variety of end connections available

Standard Materials of Construction

Item	Component	Body Material
		Material Grade/ASTM Specification
1	Body	316 SS
		F316 SS/A182
2	Element	316 SS/A479
		Sintered 316 SS or strainer 316 SS

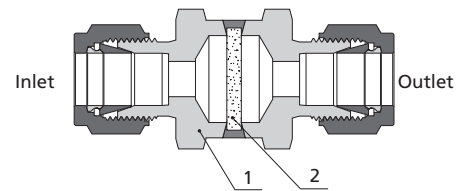

FW Series Sintered Filter Shown

Pressure vs. Temperature

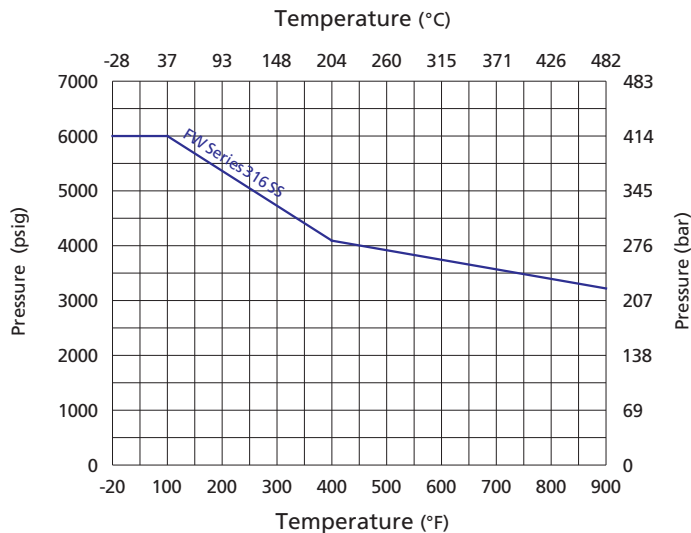

Filter Elements

Sintered

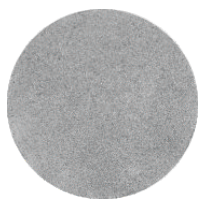

- ⦿ 316 SS powder metallurgy
- ⦿ Sheet-shaped filter cake to trap particles as small as 0.5 µm in diameter

Combination Strainer

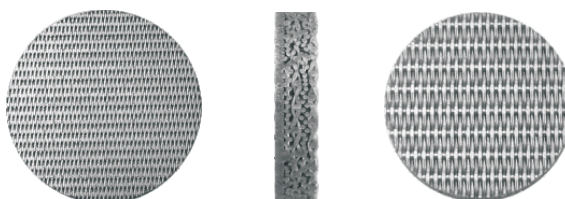

- ⦿ Multi-layer 316 SS wire meshes overlaid
- ⦿ Uniform mesh pores with high strength to allow for stable flows

Nominal Pore Size of Filter Elements

	Nominal Pore Size	Pore Size Range	Element Designator
Sintered	0.5 µm	0.5 to 2 µm	05
Strainer/ Combination Strainer	2 µm	6250 mesh	2
	7 µm	3500 mesh	7
	15 µm	800 mesh	15

Note: Filter elements remove 95% of particles larger than the nominal pore size.

Filtration Area

Filtration Area Type	Filtration Area, in. ² (mm ²)	
	Sintered	Strainer
—	0.39 (254)	0.39 (254)

Note: For FW series, sintered element available only for 0.5 µm nominal pore size, and combination strainer element option for the other sizes.

Maximum Differential Pressure of Clean Filter at 70°F (20°C)

Maximum Differential Pressure psig (bar)			
0.5 µm	2 µm	7 µm	15 µm
600 (41.4)		100 (6.9)	

Flow Data

Filtration Area Type	Element Nominal Pore Size µm	Element Type	Inlet Pressure, psig (bar)			Pressure Drop, psig (bar)		
			5 (0.34)	10 (0.68)	15 (1.0)	10 (0.68)	50 (3.4)	100 (6.8)
			Air Flow, std ft ³ /min (L/min)			Water Flow, U.S. gal/min (L/min)		
-	0.5	Sintered	0.04 (1.1)	0.06 (1.7)	0.12 (3.4)	0.01 (0.03)	0.04 (0.15)	0.12 (0.45)
	2	Strainer/ Combination Strainer	5.6 (150)	10 (280)	14 (390)	1.7 (6.4)	5.5 (20)	8.3 (31)
	7	Strainer/ Combination Strainer				3.5 (13)	11 (41)	14 (52)
	15	Strainer/ Combination Strainer				4.5 (17)	14 (52)	18 (68)

Note: Outlet is discharged to the atmosphere.

Dimensions and Ordering Information

Dimensions, in inches (millimeters), are for reference only.

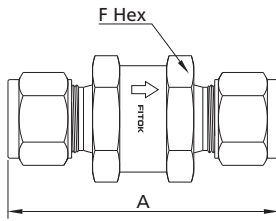

Basic Ordering Number	Connection Type and Size		Dimensions in. (mm)	
	Inlet	Outlet	A	F
FW□□-FL4-	1/4" Tube Fitting	1/4" Tube Fitting	2.15 (54.6)	1 (25.4)
FW□□-ML6-	6 mm Tube Fitting	6 mm Tube Fitting		
FW□□-FNS4-	1/4 Female NPT	1/4 Female NPT	1.57 (39.9)	
FW□□-NS4-	1/4 Male NPT	1/4 Male NPT	1.89 (48.0)	
FW□□-FR4-	1/4 Male FR	1/4 Male FR	2.04 (51.8)	

1. For FW series, sintered element available only for 0.5 µm nominal pore size, and combination strainer element option for the other nominal pore sizes.
2. FR means metal gasket seal fittings.
3. Sizes and types listed are standard. Other sizes and types are available upon request.
4. Dimensions are shown with FITOK nuts finger-tightened. All dimensions are for reference only and are subject to change. For dimensions not shown above, please contact FITOK Group or our authorized distributors.

Filters Ordering Number Description

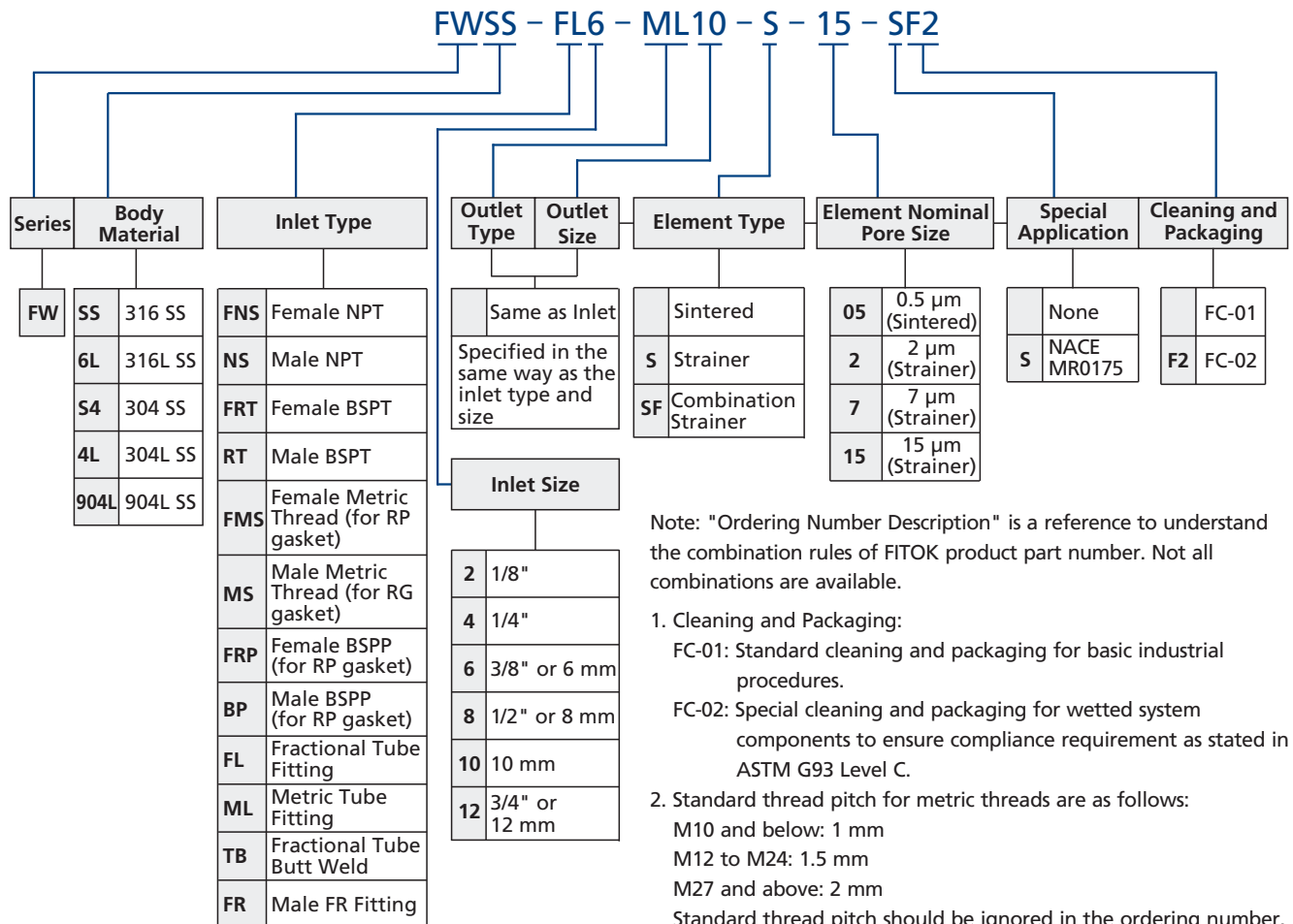

High-capacity Filters

FH Series

Introduction

FH Series High-capacity Filters feature a large filtration area, more efficient filtration, stable flow, wide medium compatibility, etc., making them suitable for high-flow pipeline systems.

Features

- ⦿ Filtration area type: 4H and 8H
- ⦿ Bypass port at filter bottom optional for the ease of sampling or purging
- ⦿ Elements equipped with retention levers for easy disassembling, cleaning and replacement
- ⦿ Standard seal materials: FKM and PTFE
- ⦿ Working pressure up to 5000 psig
- ⦿ Variety of end connections optional



Standard Materials of Construction

Item	Component	Body Material
		316 SS
Material Grade/ASTM Specification		
1	Body	F316 SS/A182
2	O-ring	FKM/FFKM/NBR/EPDM
3	Backup Ring	PTFE
4	Element	Strainer type 306 SS
5	Gasket	PTFE
6	Bonnet	316 SS/A479
7	Standard Spring Washer	Stainless Steel
8	Hexagon Thin Nut	Stainless Steel
9	Upper Retainer	316 SS/A479
10	Lever	316 SS/A479
11	Lower Retainer	316 SS/A479

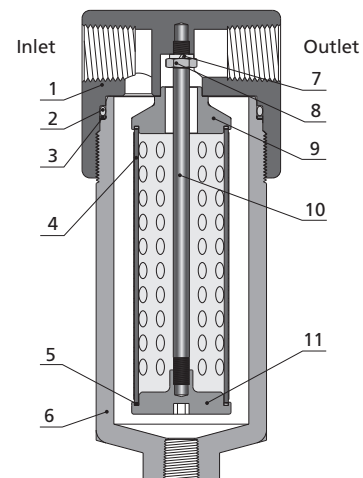

FH Series Strainer Filter Shown

Temperature Range of Sealing Materials

O-ring Material	Temperature Range °F (°C)
NBR	-20 to 212 (-28 to 100)
EPDM	-50 to 250 (-45 to 121)
FFKM	30 to 600 (-1 to 315)
FKM	-4 to 400 (-20 to 204)

Pressure vs. Temperature

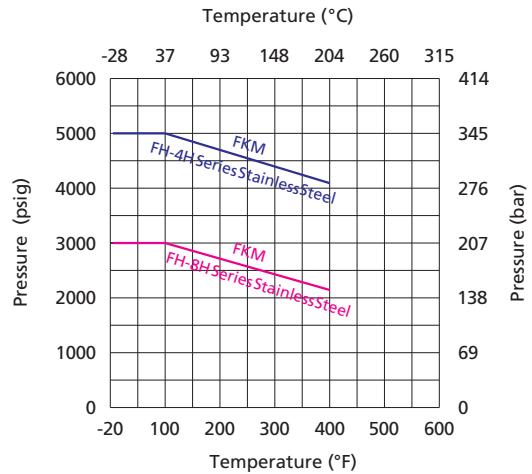

Note: For Pressure vs. Temperature curves for other seal materials listed above, please contact FITOK or our authorized distributors.

Filter Elements

strainer (25 µm)



strainer (150 µm)

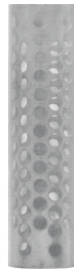

- ☉ 316 SS wire meshes and metal framework
- ☉ Uniform mesh pores to provide larger filtration area and more stable flows

Nominal Pore Size of Filter Elements

	Nominal Pore Size	Pore Size Range	Element Designator
Strainer	25 µm	500 mesh	25
	100 µm	140 mesh	100
	150 µm	100 mesh	150
	250 µm	60 mesh	250
	450 µm	40 mesh	450

Note: Filter elements remove 95% of particles larger than the nominal pore size.

Filtration Area

Filtration Area Type	Filtration Area, in. ² (mm ²)
	Strainer
4H	10.70 (6908)
8H	17.02 (10980)

Note: Strainer element available for FH series, and sintered or non-metallic element optional upon customers' requests.

Maximum Differential Pressure of Clean Filter at 70°F (20°C)

Maximum Differential Pressure psig (bar)				
25 µm	100 µm	150 µm	250 µm	450 µm
1000 (69.0)				

Flow Data

Filtration Area Type	Element Nominal Pore Size µm	Element Type	Inlet Pressure, psig (bar)		
			0.14 (2)	0.34 (5)	0.55 (8)
			Air Flow, std m ³ /h		
4H	25, 100, 150, 250, 450	Strainer	5	8.3	10.4
8H	25, 100, 150, 250, 450	Strainer	8.4	14	18.9

Note: Outlet is discharged to the atmosphere.

Dimensions and Ordering Information

Dimensions, in inches (millimeters), are for reference only.

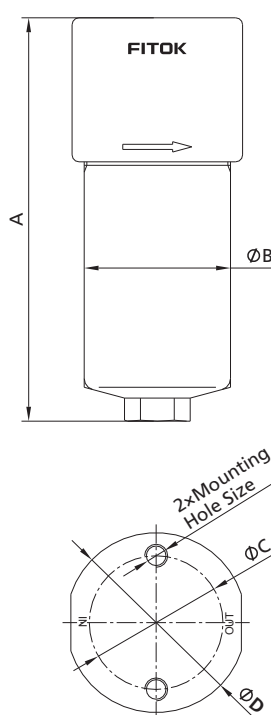

Basic Ordering Number	Connection Type and Size		Filtration Area Type	Dimensions in. (mm)				
	Inlet	Outlet		A	ØB	ØC	ØD	Mounting Hole Size
FH□□-FNS4-S-□□	1/4 Female NPT	1/4 Female NPT	4A	2.29 (58.2)	1.61 (41)	1.95 (49.5)	1.94 (49.4)	M8 × 1 - 6H threads 0.47" (12 mm) deep, pores 0.63" (16 mm) deep
FH□□-FRT4-S-□□	1/4 Female BSPT	1/4 Female BSPT						
FH□□-FRP4-S-□□	1/4 Female BSPP	1/4 Female BSPP						
FH□□-FNS6-S-□□	3/8 Female NPT	3/8 Female NPT	8A	6.89 (175)	2.5 (63.5)	2.28 (58)	3.07 (78)	M10 × 1.5 - 6H threads 0.59" (15 mm) deep, pores 0.71" (18 mm) deep
FH□□-FRT6-S-□□	3/8 Female BSPT	3/8 Female BSPT						
FH□□-FRP6-S-□□	3/8 Female BSPP	3/8 Female BSPP						
FH□□-FNS8-S-□□	1/2 Female NPT	1/2 Female NPT	8A	6.89 (175)	2.5 (63.5)	2.28 (58)	3.07 (78)	M10 × 1.5 - 6H threads 0.59" (15 mm) deep, pores 0.71" (18 mm) deep
FH□□-FRT8-S-□□	1/2 Female BSPT	1/2 Female BSPT						
FH□□-FRP8-S-□□	1/2 Female BSPP	1/2 Female BSPP						

Filters Ordering Number Description

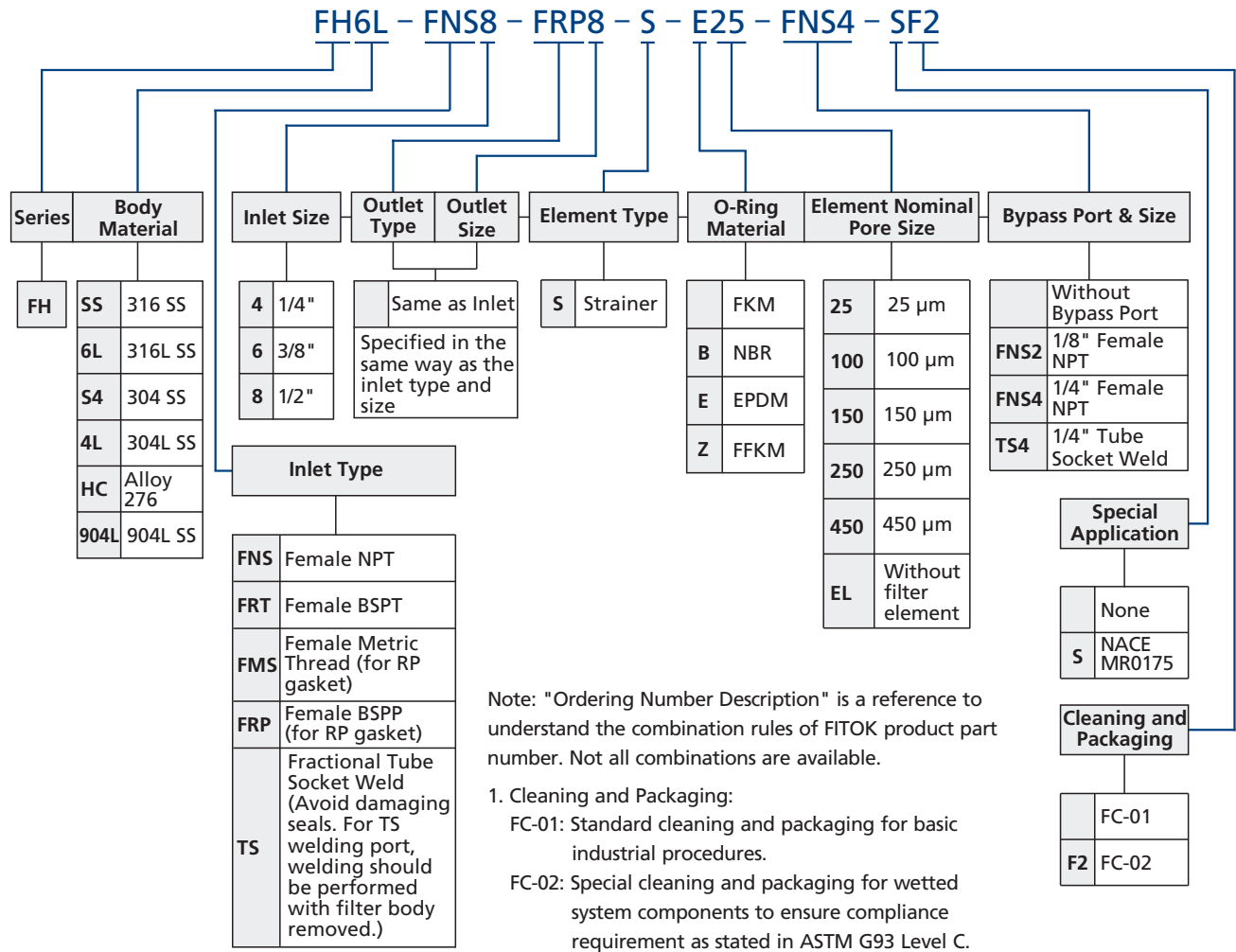

Elements Ordering Number Description

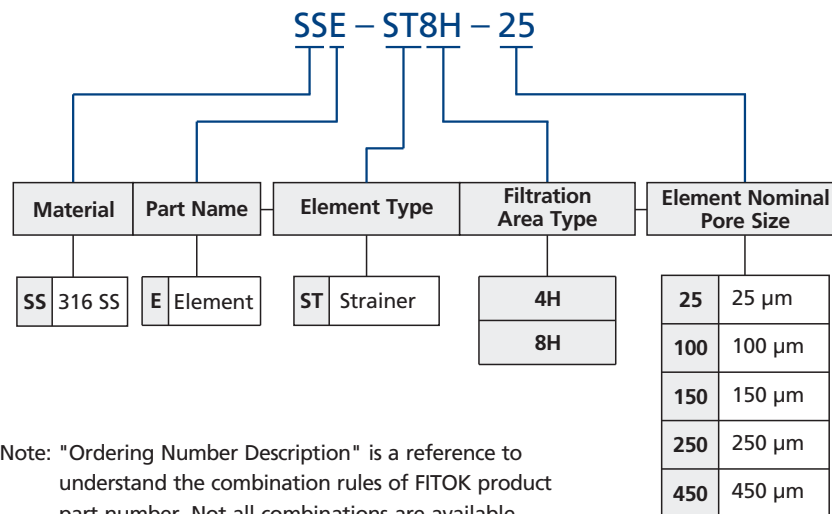

info@fitok.com
www.fitok.com

FK-IC-GV-13-EN-240112