



HIGH PURITY REGULATORS

Microelectronics Product Line

Catalog 4508/USA
October 2003



VERIFLO
ISO 9001 Certified

High Purity Regulators

Microelectronics Product Line

Catalog 4508/USA
October 2003

table of contents

Veriflo Division	1
SMSQ2Micro 1-1/2" & 1-1/8"	2 - 3
SQ2Micro	4 - 5
SQ2Micro 130E	6 - 7
SQ130E	8 - 9
SQ140E	10 - 11
SQ420E	12 - 13
SQB	14 - 15
SQ60	16 - 17
SQ60SA	18 - 19
SQHP	20 - 21
959TDR & NPR959	22 - 23
735TDR & NPR735	24 - 25
QR4000	26 - 29
NPR4000	30 - 31
HFR900W	32 - 33
SPR860	34 - 35
BFR5K	36 - 37
SQ Servo	38 - 41
Parker Hannifin Corporation	42



Parker Hannifin Corporation
Veriflo Division
250 Canal Boulevard
Richmond, CA 94804-0034
Telephone 510.235.9590
Fax 510.232.7396
<http://www.veriflo.com>



VERIFLO DIVISION



Veriflo Division, Parker Hannifin Corporation is a leading manufacturer of precision valves, regulators and surface mount components for the control and application of liquids and gases used in the fabrication of semiconductors, as well as in the chemical and petrochemical industries.

A Leading Manufacturer Of Precision Valves, Regulators & Surface Mount Components

Veriflo has maintained industry leadership over the past 95 years through innovative engineering, manufacturing and by placing a premium on quality customer care.

The division maintains two state-of-the-art Class 10 Clean Rooms at its Richmond, CA, facility and has adopted a corporate wide "Lean Manufacturing" philosophy, which is delivering greater value to the customer by eliminating wasteful steps through continuous improvement activities.

Veriflo Division's two manufacturing facilities develop and manufacture applications for the Semiconductor/High Purity and Instrument/Analyzer industries.

With the focus of maintaining the highest industry standards,

Maintained Industry Leadership By Placing A Premium On Quality Customer Care

Veriflo Division has achieved an ISO 9001 registration at both its Richmond, CA manufacturing plant and at its Carson City, NV facility. This certification confirms Veriflo's commitment to quality and excellence as recognized by the international community.

The Instrumentation Group of Parker Hannifin specializes in high quality, critical flow components for world-wide process instrumentation, ultra-high-purity, medical, analytical and biopharmaceutical applications.

Parker's Instrumentation Group has ten manufacturing plants and over 300 authorized distributor locations around the world to provide local inventory and technical support. Key markets for the Instrumentation Group include: Chemical Process, Power Generation, Oil and Gas Exploration, Semiconductor Manufacturing, Biomedical, and Analytical Equipment.

Note: For further information on Veriflo Division and or its product line visit the division web site at www.veriflo.com. For more information on Parker Hannifin Corporation visit the corporation's web site at www.parker.com.



SMSQ2Micro & SMSQ2Micro130E

1-1/8" & 1-1/2"
Regulator



Parker Hannifin Corporation's Veriflo Division presents the SMSQ2Micro 1-1/2" & 1-1/8". The SMSQ2Micro part of the process proven SQ product line, provides excellent stability and sensitivity for today's modular surface mount systems.

The SMSQ2Micro provides all the performance benefits to modular designs including: springless tied diaphragm design; extraordinary transient response performance; and low particle counts.



features

- ▶ Meets SEMI Modular Interface specifications.
- ▶ Flow capacities up to 30 SLPM, depending on model selection.
- ▶ Standard Hastelloy C-22[®] Poppet and Diaphragm.
- ▶ Gas system footprint reduction.
- ▶ Reduced wetted volume.
- ▶ Ease of component retrofit.
- ▶ Standard surface finish 5 micro inch Ra (.13 micro meter).
- ▶ No springs or threads are exposed to the wetted area.
- ▶ Standard full internal electropolish.
- ▶ Available in 1-1/2" and 1-1/8" base size.

materials of construction

Wetted

Body "VeriClean", Veriflo's high purity type 316L Stainless Steel™
 Seat PCTFE, optional Vespel[®]
 Diaphragm Hastelloy C-22[®]
 Poppet Hastelloy C-22[®]
 Compression Member "VeriClean", Veriflo's high purity type 316L Stainless Steel, optional Hastelloy C-22[®]

Non-Wetted

Cap. Nickel Plated Brass
 Adjusting screw 316L Stainless Steel
 Knob SQMicro (blue). ABS Plastic

operating conditions

Maximum inlet pressure 250 psig (17.2 barg)
 Outlet pressure. -10 in Hg to 60 psig (5 psia, 250 torr to 4 barg)
 Temperature -40°F to 150°F (-40°C to 66°C)

surface finish

Standard Ra 5 micro inch (.13 micro meter) or less

functional performance

Design proof pressure 375 psig (26 barg)
 Design burst pressure: 750 psig (52 barg)
 Flow capacity:
 SMSQ2Micro Cv 0.06
 SMSQ2Micro130E. Cv 0.15
 (SEMI Flow Coefficient Test# F-32-0998)

Design Leak Rate:

Across Seat 5×10^8 cc/sec He
 Inboard 2×10^{10} cc/sec He
 Outboard 2×10^9 cc/sec He

internal volume

4.0 cc

standard connections

SEMI modular interface

approximate weight

0.75 lbs (0.34 kgm)



SMSQ2Micro & SMSQ2 Micro 130E

1-1/8" & 1-1/2" Regulator

Dimensional Drawing

All dimensions are reference and nominal.

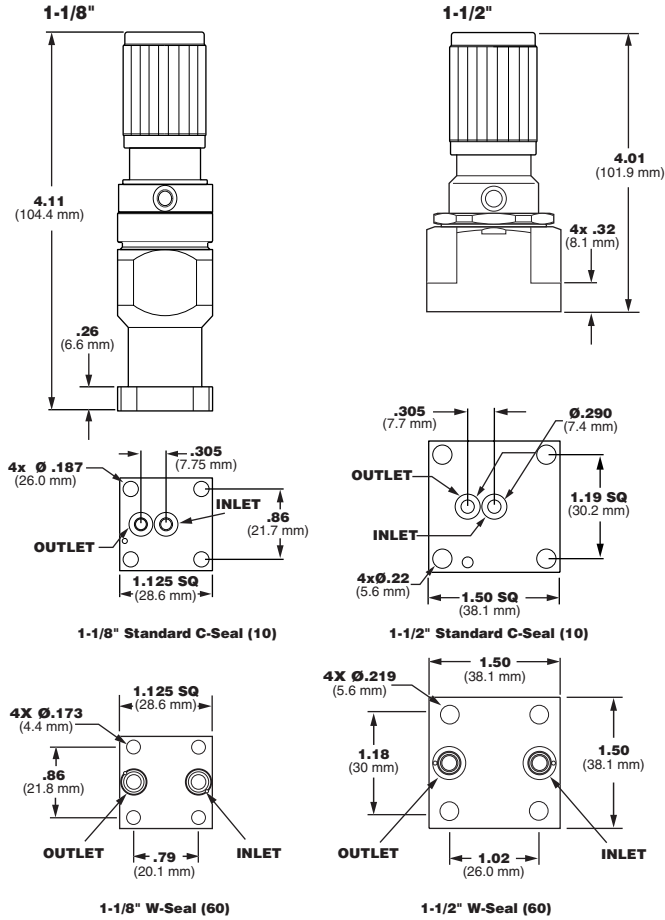

Flow Curves

SMSQ2 Micro 1-1/2" Flow Curve

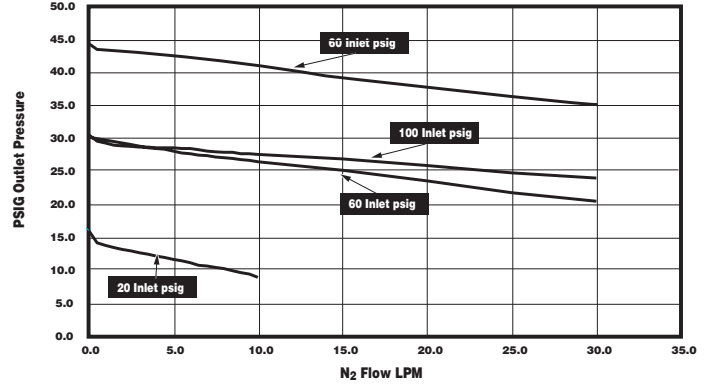

SMSQ2 Micro 1-1/8" Flow Curve

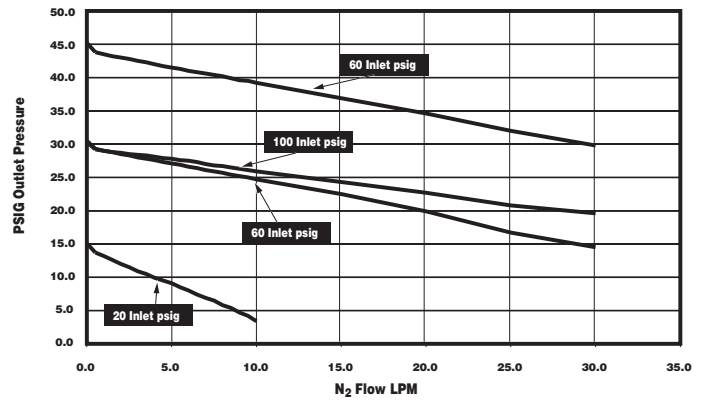

Ordering Information

SMSQ2MICRO 30 10 SS

BASIC SERIES

SMSQ2MICRO
SMSQ2MICRO130E

RANGE

30 = 0 - 30 psig
60 = 0 - 60 psig

OPTIONAL FEATURES

SS = Stainless Steel Internals**
TH = Hastelloy C-22® Trim***
VESP = Vespel® Seat*

BASE SIZE

blank = 1-1/2" interface
2 = 1-1/8" interface

PORTING

10 = = 2 Port, C-Seal
11 = = 2 Port, High Flow C-Seal
20 = = 3 Port, C-Seal
30 = = 3 Port, High Flow C-Seal
60 = = "W" Seal

Preset available upon request

* Recommended for Nitrous Oxide (N₂O) Service.
** Recommended for Carbon Monoxide (CO) or Nickel Carbonyl Ni(CO)₄ Service
*** Hastelloy C-22® Trim (TH) includes compression member.

Hastelloy C-22® is a registered trademark of Haynes International, Inc.
Vespel® is a registered trademark of DuPont Company.

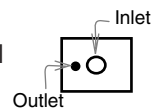



Parker Hannifin Corporation's Veriflo Division presents the SQ2Micro, which is part of the process proven SQ product line. The SQ2Micro is a revolutionary, miniature, high performance, point-of-use regulator with a foot-print designed specifically to reduce semiconductor system real estate. The improved alignment of the SQ2Micro allows for even better performance than it's predecessor, the SQMicro

The SQ2Micro provides excellent repeatability, stability, and sensitivity. It shows extraordinary response to step function changes. The outstanding low particle counts of the other SQ's are duplicated in the SQ2Micro.

The SQ2Micro's miniature size allows for precise process gas regulation without increasing the size of the tool gas box.



features

- ▶ Standard Hastelloy C-22® Poppet and Diaphragm.
- ▶ Miniature footprint, internal volume, and surface area.
- ▶ Dimensions are interchangeable with Veriflo Division Quantum valves.
- ▶ No springs or threads are exposed to the wetted area.
- ▶ Standard full internal electropolish.



▶ **materials of construction**

Wetted
 Body "VeriClean", Veriflo's high purity type 316L Stainless Steel™, Hastelloy C-22®
 Seat PCTFE, optional Vespel®
 Diaphragm Hastelloy C-22®
 Poppet Hastelloy C-22®
 Compression Member "VeriClean", Veriflo's high purity type 316L Stainless Steel, optional Hastelloy C-22®

Non-Wetted
 Cap Nickel Plated Brass
 Adjusting screw 416 Stainless Steel
 Knob (Blue) ABS Plastic

▶ **operating conditions**
 Maximum inlet pressure 250 psig (17 barg)
 Outlet pressure 10 psia to 60 psig (500 torr to 4 barg)
 Temperature -40°F to 150°F (-40°C to 66°C)

▶ **surface finishes**
 Standard Ra 5 micro inch (.13 micro meter) or less

▶ **functional performance**
 Design proof pressure 375 psig (26 barg)
 Design burst pressure 750 psig (52 barg)
 Flow capacity C_v 0.06 (SEMI Flow Coefficient Test #F-32-0998)

Design Leak Rate:
 Across Seat 5 x 10⁻⁸ cc/sec He
 Inboard 2 x 10⁻¹⁰ cc/sec He
 Outboard 2 x 10⁻⁹ cc/sec He

▶ **internal volume**
 2.56 cc

▶ **standard connections**
 Any combination of FS male and/ or female fittings.
 1/4" Gland to gland length 2.78 ± .02 in. (70.6 ± .05 mm)

1/4" tube stubs inlet and outlet available
 End to end length 2.25 ± .03 (57.1 ± .05 mm)

▶ **approximate weight**
 0.9 lbs. (0.42 kgm)

SQ2Micro

Dimensional Drawing

All dimensions are reference and nominal.

SQ2Micro

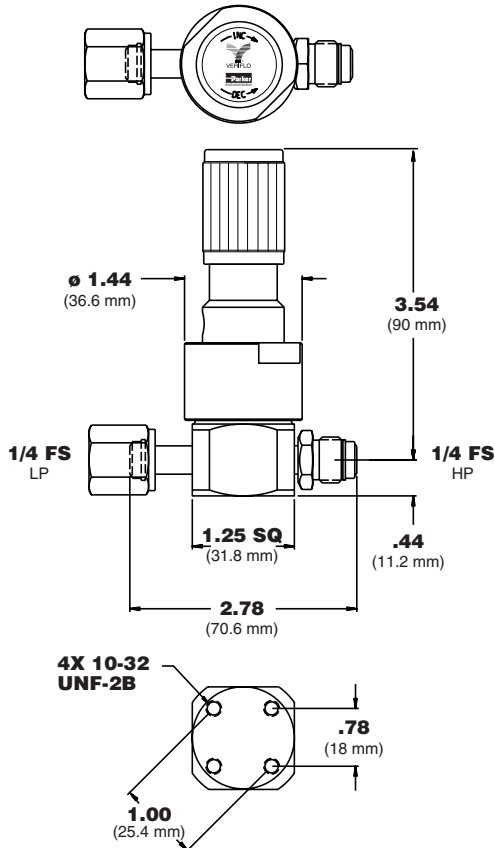

SQ2Micro "A"

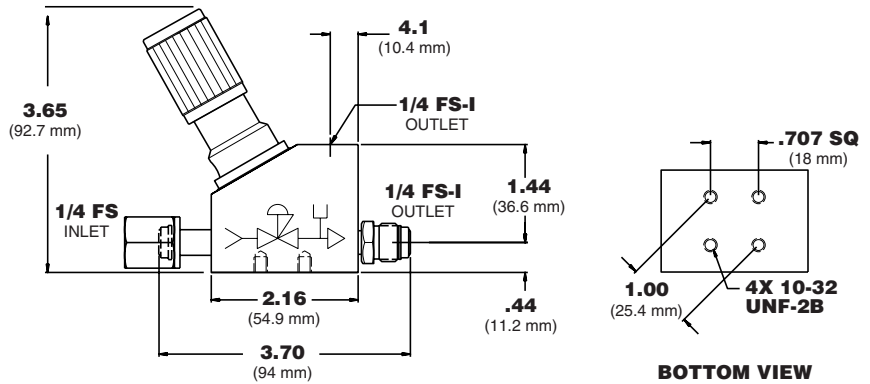

Flow Curves

SQ2Micro Flow Curve

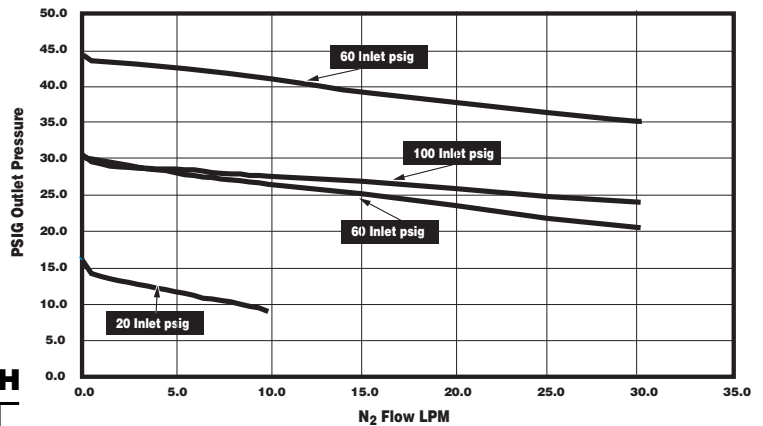

Ordering Information

SQ2MICRO30 2P FSMF TH

BASIC SERIES

SQ2MICRO30 = 0-30 psig
SQ2MICRO60 = 0-60 psig

MATERIAL

= 316L Stainless Steel (standard)
H = Hastelloy C-22[®]

PORTING

2P = 2 Ports
3P = 3 Ports

* Recommended for (N₂O) Service

** Note: (I) = Internal Face Seal

† Recommended for Carbon Monoxide (CO) or Nickel Carbonyl Ni(CO)₄ Service

Hastelloy C-22[®] is a registered trademark of Haynes International, Inc.
Vespel[®] is a registered trademark of DuPont

OPTIONAL FEATURES

A = "A" Style Body
SS = Stainless Steel Internals †
TH = Hastelloy C-22[®] Trim (Compression Member)
VESP = Vespel[®] Seat*

CONNECTIONS

FSMM = 1/4" Face Seal Male In and Out
FSFF = 1/4" Face Seal Female In and Out
FSFM = 1/4" Face Seal Female In Male Out
FSMF = 1/4" Face Seal Male In Female Out
TS = 1/4" Tube Stub

FOR "A" STYLE ONLY:

FSMIM = 1/4" Face Seal Male In and Out**
FSFIF = 1/4" Face Seal Female In and Out**
FSFIM = 1/4" Face Seal Female In Male Out**
FSMIF = 1/4" Face Seal Male In Female Out**

Parker
Instrumentation

SQ2Micro130E

Miniature Pressure Regulator



Parker Hannifin Corporation's Veriflo Division presents the SQ2Micro130E. The SQ2Micro regulator design is based on the process proven SQMicro Series. The SQ2Micro130E incorporates a new poppet and seat allowing increased flow capacity of 100 slpm.

This is an increase from the standard SQMicro (0-3 slpm) and the SQMicroHF (0-30 slpm).

Space savings are apparent both in regulator face-seal to face-seal dimensions and body width, which allows closer spacing of components and process lines. In a state-of-the-art gas box, where the SQ2Micro is intermixed with Veriflo Quantum 1/4 inch valves and mass flow controllers, maximum gas box density is permitted without sacrificing performance or field serviceability.



features

- ▶ Standard Hastelloy C-22® Poppet and Diaphragm.
- ▶ Minimized footprint, internal volume, and surface area.
- ▶ Delivers most of the outstanding performance of the SQ60, despite the size reduction.
- ▶ Dimensions are interchangeable with Veriflo Division Quantum valves.
- ▶ No springs or threads are exposed to the wetted area.
- ▶ Standard full internal electropolish.

materials of construction

Wetted

Body "VeriClean", Veriflo's high purity type 316L VAR Stainless Steel™, HastelloyC-22®
 Seat PCTFE, optional Vespel®
 Diaphragm Hastelloy C-22®
 Poppet Hastelloy C-22®
 Compression member "VeriClean", Veriflo's high purity type 316L VAR Stainless Steel™, optional Hastelloy C-22®

Non-Wetted

Cap Nickel Plated Brass
 Adjusting screw 416 Stainless Steel
 Knob (Black). ABS Plastic

operating conditions

Maximum inlet pressure 250 psig (10 barg)
 Outlet pressure 10 in Hg to 60 psig (250 torr) to (4 barg)
 Temperature -40°F to 150°F (-40°C to 66°C)

surface finishes

Standard Ra 5 micro inch (.13 micro meter) or less

functional performance

Design proof pressure 375 psig (26 barg)
 Design burst pressure 750 psig (52 barg)
 Flow capacity C_v 0.15 (SEMI Flow Coefficient Test #F-32-0998)

Design Leak Rate:

Across Seat 5 x 10⁻⁸ scc/sec He
 Inboard 2 x 10⁻¹⁰ scc/sec He
 Outboard 2 x 10⁻⁹ scc/sec He

internal volume

4.21 cc

standard connections

Any combination of FS male and/or female fittings.
 1/4" Gland to gland length 2.78 ± .02 in. (70.6 ± .05 mm)
 1/4" tube stubs inlet and outlet available.
 End to end length 2.25 ± .03 in. (57.1 ± .05 mm)

approximate weight

0.9 lbs. (0.42 kgm)



SQ2Micro130E

Dimensional Drawing

All dimensions are reference and nominal.

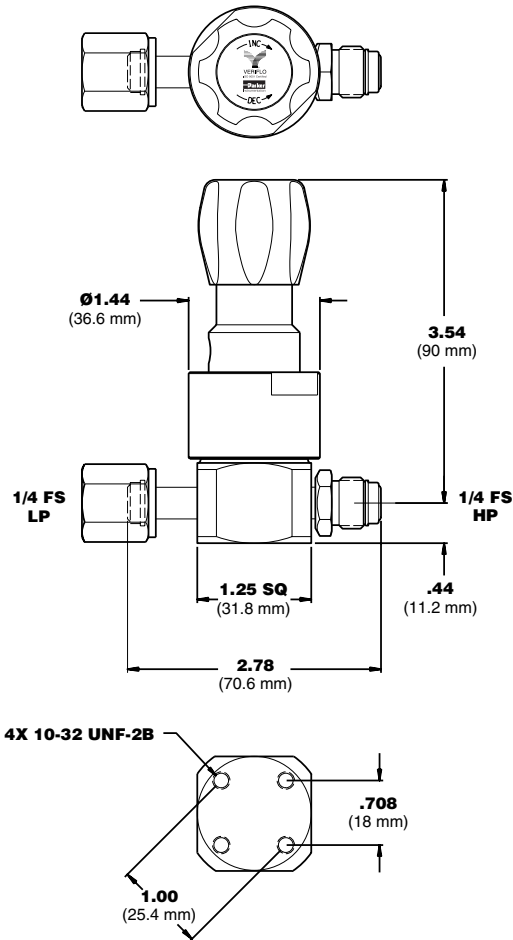

Flow Curves

Inlet Pressure: 90 psig

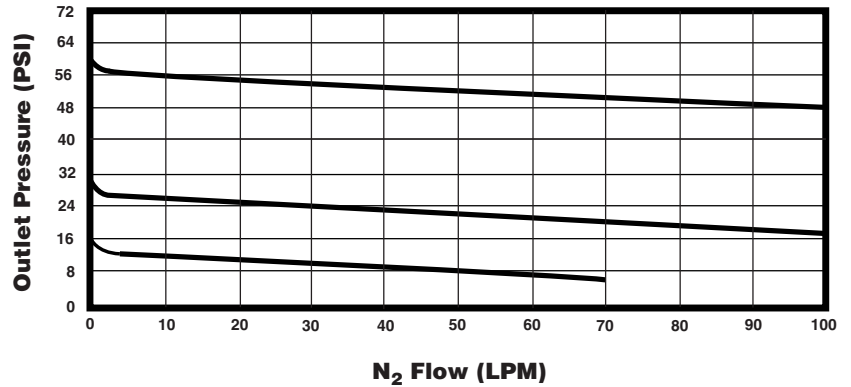

SQMicro "A" Style Body Dimensions

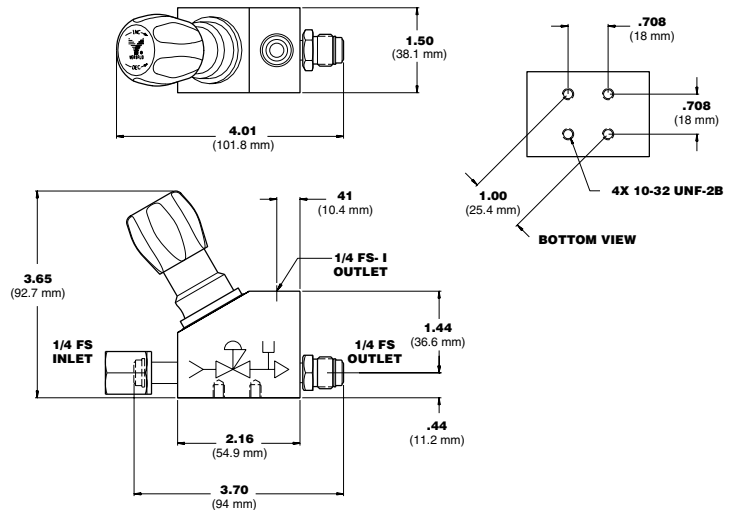

Ordering Information

SQ2MICRO130E30 2P FSMF TH

BASIC SERIES

SQ2MICRO130E30 = 0 - 30 psig
 SQ2MICRO130E60 = 0 - 60 psig

MATERIAL

= 316L VAR Stainless Steel (Standard)
 H = Hastelloy C-22[®]

PORTING

2P = 2 Ports
 3P = 3 Ports

OPTIONS

A = "A" Style Body
 SS = Stainless Steel Internals †
 TH = Hastelloy C-22[®] Trim (Compression Member)
 VESP = Vespel[®] Seat*

CONNECTIONS

FSMM = 1/4" Face Seal Male In and Out
 FSFF = 1/4" Face Seal Female In and Out
 FSFM = 1/4" Face Seal Female In Male Out
 FSMF = 1/4" Face Seal Male In Female Out
 TS = 1/4" Tube Stub

FOR "A" STYLE ONLY:

FSMIM = 1/4" Face Seal Male In and Out**
 FSFIF = 1/4" Face Seal Female In and Out**
 FSFIM = 1/4" Face Seal Female In Male Out**
 FSMIF = 1/4" Face Seal Male In Female Out**

* Recommended for Nitrous Oxide (N₂O) Service

** Note: (I) = Internal Face Seal

† Recommended for Carbon Monoxide (CO) or Nickel Carbonyl Ni(CO)₄ Service

Hastelloy C-22[®] is a registered trademark of Haynes International, Inc.
 Vespel[®] is a registered trademark of DuPont Company.



SQ130E

High Performance Point-Of-Use Regulator



Parker Hannifin Corporation's Veriflo Division presents the SQ130E. This regulator is a high flow, springless and threadless, point-of-use regulator designed to be used in process gas cabinets for gas companies, equipment manufacturers, and end users. The SQ130E has a C_v four times greater (.2 C_v) than the process proven SQ60, from which the SQ130E was developed.

The SQ130E provides precise control of process gas pressure at or near the tool for flow rates of up to 300 slpm at 200 psig inlet. The result is a stable flow and pressure to the mass flow controller.

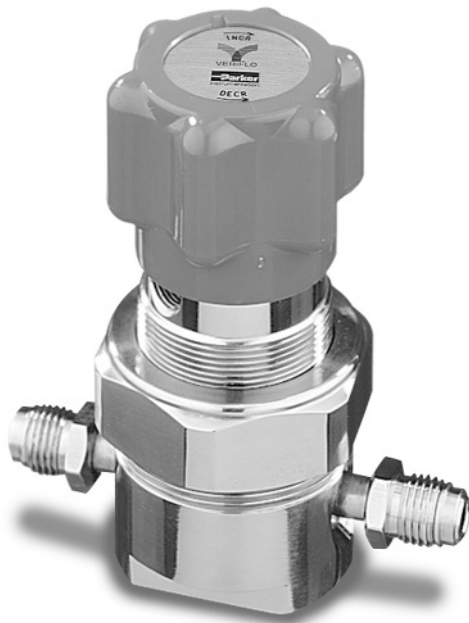

features

- ▶ Increased flow capacity
- ▶ Standard Hastelloy C-22[®] Poppet and Diaphragm.
- ▶ Tied-diaphragm for added safety.
- ▶ Hurricane cleaning for "near-absolute" contamination control.
- ▶ Metal-to-metal, diaphragm-to-body seal.
- ▶ No springs or threads are exposed to the wetted area.



materials of construction

Wetted

Body "VeriClean", Veriflo's high purity type 316L Stainless Steel™, Hastelloy C-22[®]
 Seat PCTFE, optional Vespel[®]
 Diaphragm Hastelloy C-22[®]
 Poppet Hastelloy C-22[®]
 Compression Membrane . . . "VeriClean", Veriflo's high purity type 316L Stainless Steel™, optional Hastelloy C-22[®]

Non-Wetted

Cap Brass, Nickel Plated
 Nut 316L Stainless Steel
 Knob (Blue) ABS Plastic

operating conditions

Maximum inlet pressure 1000 psig (70 barg)
 Outlet pressure 0-30 psig (2 barg)
 0-50 psig (3 barg), 0-100 psig (7 barg)
 Temperature -40°F to 150°F (-40°C to 66°C)

surface finishes

Standard Ra 10 micro inch (.25 micro meter) or less
 Optional Ra EV = 5 micro inch (.13 micro meter) or less

functional performance

Design proof pressure 1300 psig (89.7 barg)
 Design burst pressure 3000 psig (207 barg)
 Flow Capacity C_v 0.2
 (SEMI Flow Coefficient Test #F-32-0998)

Design Leak Rate:

Across Seat 5×10^{-8} scc/sec He
 Inboard 2×10^{-10} scc/sec He
 Outboard 2×10^{-9} scc/sec He

internal volume

6.19 cc

standard connections

Any combination of FS male and/or female fittings:
 1/4" Gland to gland length $3.7 \pm .02$ in.
 (94.0 \pm .5 mm)

1/4" tube stubs inlet and outlet available

End to end length $3.7 \pm .03$ (94.0 \pm .8 mm)

approximate weight

1.5 lbs. (.7 kg)

SQ130E

Dimensional Drawing

All dimensions are reference and nominal.

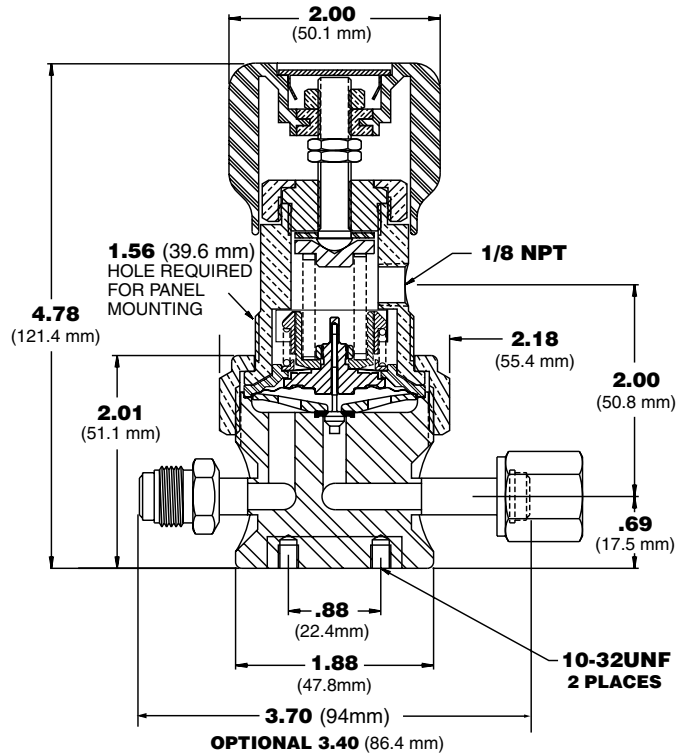

Flow Curves

SQ130E100

Inlet Pressure = 250 psig

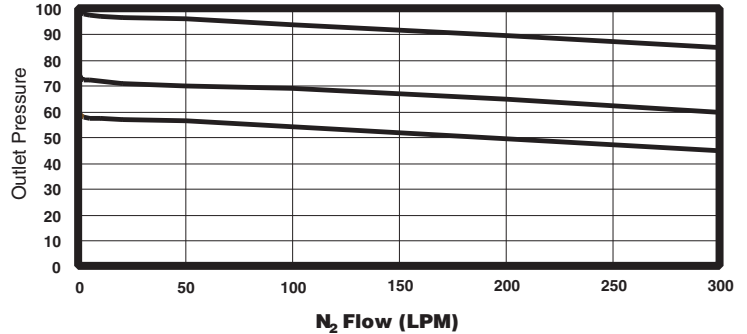

Porting Configurations

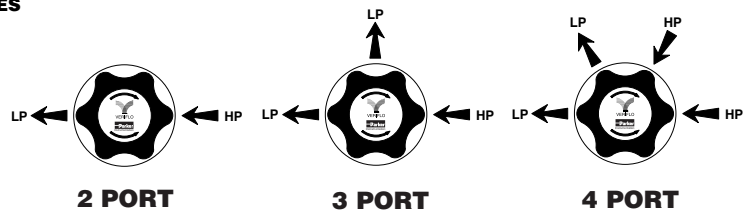

Ordering Information

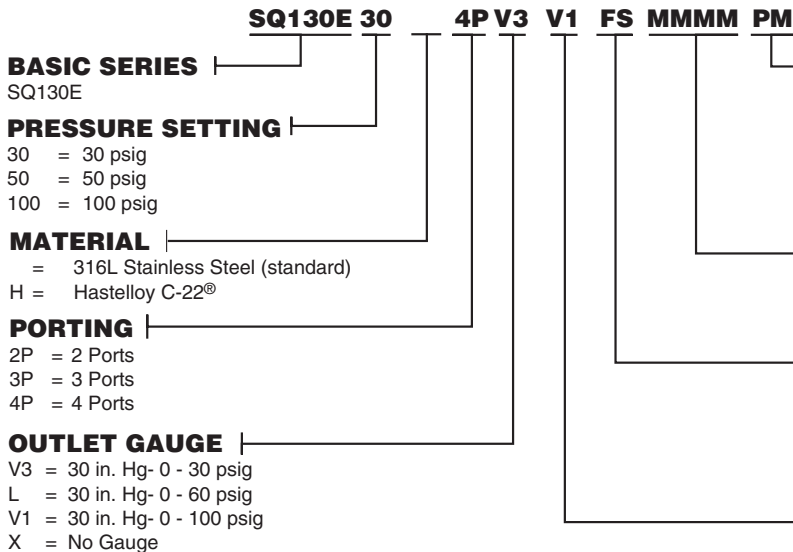

OPTIONAL FEATURES

DO = Dome Loaded
PM = Panel Mount
SS = Stainless Steel Internals †
TH = Hastelloy C-22® Trim (Compression Member)
VESP = Vespel® Seat*
3.4 = 3.4" Optional End-to-End Dimension

PORT CONFIGURATION

M = Male
F = Female
I = Internal Face Seal Female (1/4" Only)

PORT STYLE

FS = 1/4" Face Seal
FS8 = 1/2" Face Seal
TS = 1/4" Tube Stub
TS6 = 3/8" Tube Stub
TS8 = 1/2" Tube Stub

INLET GAUGE

V1 = 30 in. Hg- 0 - 100 psig
2 = 0 - 200 psig
4 = 0 - 400 psig
X = No Gauge

* Recommended for Nitrous Oxide (N₂O) Service
† Recommended for Carbon Monoxide (CO) or Nickel Carbonyl Ni(CO)₄ Service

Hastelloy C-22® is a registered trademark of Haynes International, Inc.
Vespel® is a registered trademark of DuPont Company.

Parker
Instrumentation

SQ140E

High Performance Point-Of-Use Regulator



Parker Hannifin Corporation's Veriflo Division presents the SQ140E. The SQ140E was developed in response to the need for high performance point-of-use regulators for modern semiconductor processing. It was designed from scratch with no preconceptions or ties to older high pressure designs.

Precise control of gas pressure at or near the tool served, makes possible stable process control by a mass flow controller. The resulting accurate delivery from the mass flow controller goes right to the bottom line in process repeatability.



features

- ▶ Standard Hastelloy C-22[®] Poppet and Diaphragm.
- ▶ High flow capacity with minimal pressure drop and low supply pressure.
- ▶ Tied-diaphragm for added safety.
- ▶ Capable of operating at a wide range of flows from 0.1 cc/min to 100 liters/min with only 5 psig pressure drop.
- ▶ Design and materials of construction ensure compatibility with the high flow of corrosive gases.
- ▶ No springs or threads are exposed to the wetted area.

materials of construction

Wetted

Body "VeriClean", Veriflo's high purity type 316L VAR Stainless Steel[™], Hastelloy C-22[®]
 Seat PCTFE, optional Vespel[®]
 Diaphragm Hastelloy C-22[®]
 Poppet Hastelloy C-22[®]
 Compression Member "VeriClean", Veriflo's high purity type 316L VAR Stainless Steel, optional Hastelloy C-22[®]

Non-Wetted

Cap Nickel Plated Brass
 Nut Nickel Plated Brass
 Knob (Blue) ABS Plastic

operating conditions

Maximum inlet pressure 250 psig (17 barg)
 optional 750 psig (52 barg)
 Outlet pressure 0-30 psig (2 barg),
 0-50 psig (3 barg), 0-100 psig (7 barg)
 Temperature -40°F to 150°F (-40°C to 66°C)

surface finishes

Standard Ra 10 micro inch
 (.25 micro meter) or less
 Optional Ra EV=5 micro inch
 (.13 micro meter) or less

functional performance

Design proof pressure 375 psig (26 barg)
 Design burst pressure 750 psig (52 barg)
 Flow capacity C_v .25
 (SEMI Flow Coefficient Test #F-32-0998)

Design Leak Rate:

Across Seat 5 x 10⁻⁸ scc/sec He
 Inboard 2 x 10⁻¹⁰ scc/sec He
 Outboard 2 x 10⁻⁹ scc/sec He

internal volume

19.02 cc

standard connections

Any combination of FS male and/or female fittings:
 1/4" Gland to gland length 4.64 ± .02 in.
 (117.9 ± .05 mm)
 1/2" Gland to gland length 5.59 ± .02 in.
 (142 mm ± .5 mm)

approximate weight

4 lbs 10 oz. (2.1 kg)



SQ140E

Dimensional Drawing

All dimensions are reference and nominal.

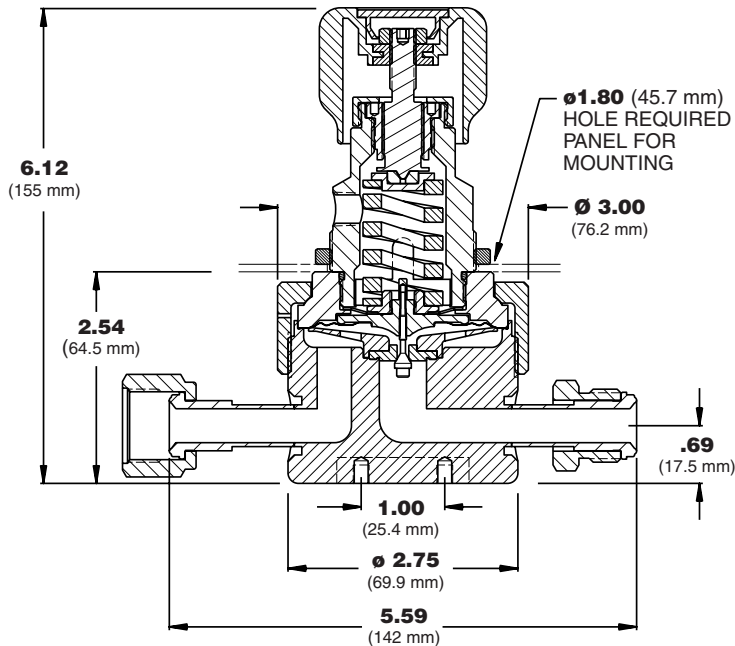

End to End Dimensional Chart

1/4" FS	4.64" (117.9 mm)
1/2" FS	5.59" (142 mm)
1/2" TS	4.64" (117.9 mm)

Flow Curves

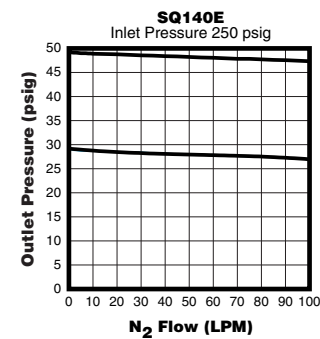
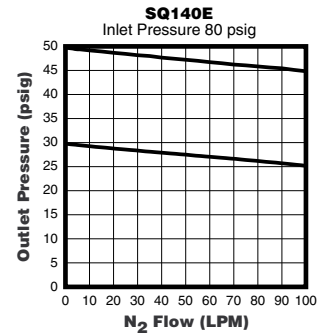

Porting Configurations

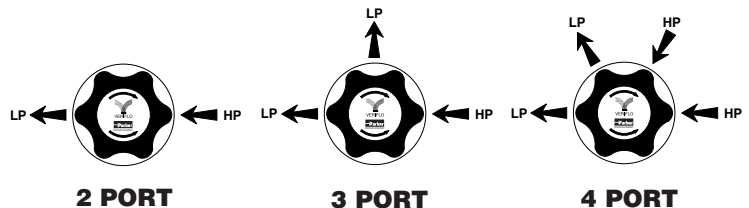

Ordering Information

SQ140E 30 4P V3 V1 F S M M M F P M

BASIC SERIES

SQ140E

PRESSURE SETTING

30 = 30 psig
50 = 50 psig
100 = 100 psig

MATERIAL

= 316L VAR Stainless Steel (standard)
H = Hastelloy C-22®

PORTING

2P = 2 Ports
3P = 3 Ports
4P = 4 Ports

OUTLET GAUGE

V3 = -30 in. Hg- 0 - 30 psig
L = -30 in. Hg- 0 - 60 psig
V1 = -30 in. Hg- 0 - 100 psig
X = No Gauge

OPTIONAL FEATURES

PM = Panel Mount
SS = Stainless Steel Internals †
TH = Hastelloy C-22® Trim (Compression member)
VESP = Vespel® Seat*
750 = 750 psig Max Inlet

PORT CONFIGURATION

M = Male
F = Female
I = Internal Female Face Seal (1/4" Only)

PORT STYLE

FS = 1/4" Face Seal
FS8 = 1/2" Face Seal
TS = 1/4" Tube Stubs
TS6 = 3/8" Tube Stubs

INLET GAUGE

V1 = -30 in. Hg- 0 - 100 psig
2 = 0 - 200 psig
10 = 0 - 1000 psig
X = No Gauge

* Recommended for Nitrous Oxide (N₂O) Service

† Recommended for Carbon Monoxide (CO) or Nickel Carbonyl Ni(CO)₄ Service

Hastelloy C-22® is a registered trademark of Haynes International, Inc.
Vespel® is a registered trademark of DuPont Company.



SQ420E

High Performance Point-Of-Use Regulator



Parker Hannifin Corporation's Veriflo Division presents the SQ420E. The SQ Series was developed in response to the need for high performance point-of-use regulators for modern semiconductor processing. The SQ's were designed from scratch, with no preconceptions, no ties to older high-purity designs.

Precise control of the gas discharge pressure at or near the tool served, makes possible stable process control by a mass flow controller. The resulting accurate delivery from the mass flow controller goes right to the bottom line in process repeatability.



features

- ▶ Standard Hastelloy C-22[®] Poppet and Diaphragm.
- ▶ High flow capacity with minimal pressure drop, and low supply pressure.
- ▶ Tied-diaphragm for added safety.
- ▶ Hurricane cleaning for "near absolute" contamination control.
- ▶ Capable of operating at a wide range of flows from 0.5 cc/min to more than 800 liters/min.
- ▶ Design and materials of construction ensure compatibility with high flowing corrosive gases.
- ▶ No springs or threads are exposed to the wetted area.

materials of construction

Wetted

Body "VeriClean", Veriflo's high purity type 316L VAR Stainless Steel™, Hastelloy C-22[®]
 Seat PCTFE, optional Vespel[®]
 Diaphragm Hastelloy C-22[®]
 Poppet Hastelloy C-22[®]
 Compression Member "VeriClean", Veriflo's high purity type 316L VAR Stainless Steel™, optional HastelloyC-22[®]

Non-Wetted

Cap. Nickel Plated Brass
 Nut Nickel Plated Brass
 Knob (Blue). ABS Plastic

operating conditions

Maximum inlet pressure . . . 250 psig (17.2 barg)
 Outlet pressure . . . 0-30 psig (2 barg) adjustable,
 0-50 psig (3 barg) adjustable,
 0-100 psig (7 barg) adjustable
 Temperature -40°F to 150°F (-40°C to 66°C)

surface finishes

Standard Ra 10 micro inch (.25 micro meter) or less
 Optional Ra EV=5 micro inch (.13 micro meter) or less

functional performance

Design proof pressure 375 psig (26 barg)
 Design burst pressure 750 psig (52 barg)
 Flow Capacity C_v 1.5 (SEMI Flow Coefficient Test #F-32-0998)

Design Leak Rate:

Across Seat 5 x 10⁻⁸ scc/sec He
 Inboard 2 x 10⁻¹⁰ scc/sec He
 Outboard 2 x 10⁻⁹ scc/sec He

internal volume

22.32 cc

standard connections

Any combination of FS male and/or female fittings:
 1/4" Gland to gland length 4.64 ± .02 in. (117.9 ± .5 mm)
 1/2" Gland to gland length 5.59 ± .02 in (142 mm ± .5mm)

approximate weight

4 lbs 10 oz. (2.1 kg)



SQ420E

Dimensional Drawing

All dimensions are reference and nominal.

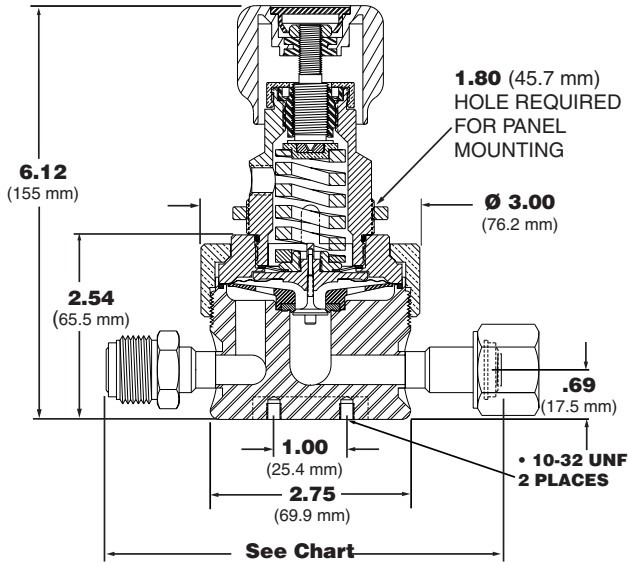

End to End Dimensional Chart

1/4" FS	4.64" (117.9 mm)
1/2" FS	5.59" (142 mm)
1/2" TS	4.64" (117.9 mm)

Flow Curves

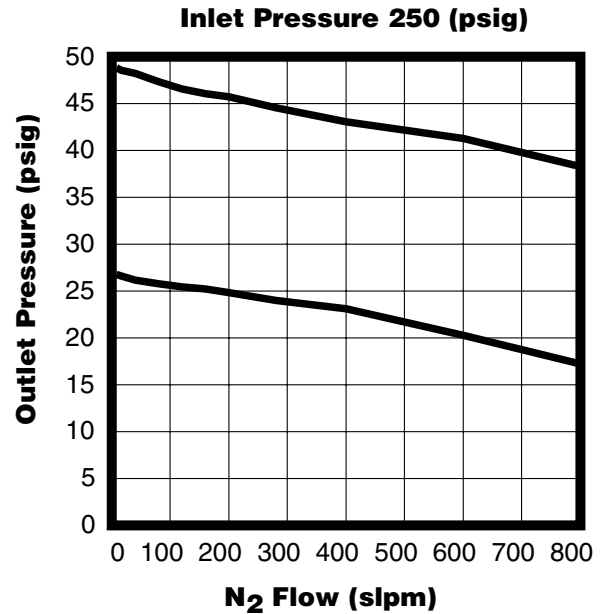

Porting Configurations

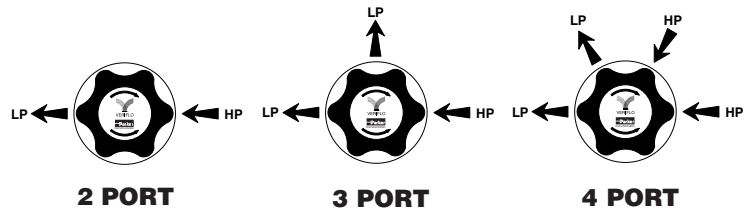

Ordering Information

<p>BASIC SERIES SQ420E</p> <p>PRESSURE SETTING 30 = 30 psig 50 = 50 psig 100 = 100 psig</p> <p>MATERIAL = 316L VAR Stainless Steel (standard) H = Hastelloy C-22®</p> <p>PORTING 2P = 2 Ports 3P = 3 Ports 4P = 4 Ports</p> <p>OUTLET GAUGE V3 = -30 in. Hg- 0 - 30 psig L = -30 in. Hg- 0 - 60 psig V1 = -30 in. Hg- 0 - 100 psig X = No Gauge</p>	<p>OPTIONAL FEATURES PM = Panel Mount TH = Hastelloy C-22® Trim (Compression Member) VESP = Vespel® Seat* SS = Stainless Steel Internals**</p> <p>PORT CONFIGURATION M = Male F = Female I = Internal Female Face Seal (1/4" Only)</p> <p>PORT STYLE FS = 1/4" Face Seal FS8 = 1/2" Face Seal TS = 1/4" Tube Stubs TS6 = 3/8" Tube Stubs</p> <p>INLET GAUGE V1 = -30 in. Hg- 0 - 100 psig 2 = 0 - 200 psig 4 = 0 - 400 psig X = No Gauge</p>
--	--

* Recommended for Nitrous Oxide (N₂O) Service
** Recommended for Carbon Monoxide (CO) or Nickel Carbonyl Ni(CO)₄ Service

Hastelloy C-22® is a registered trademark of Haynes International, Inc.
Vespel® is a registered trademark of DuPont Company.



SQB Series

Dimensional Drawing

All dimensions are reference and nominal.

End to End Dimensional Chart

1/2" FS	5.60" (142 mm)
3/4" FS	6.34" (161 mm)
1.0" FS	8.25" (210 mm)
1/2" TS	4.75" (121 mm)
3/4" TS	4.75" (121 mm)
1.0" TS	5.60" (142 mm)

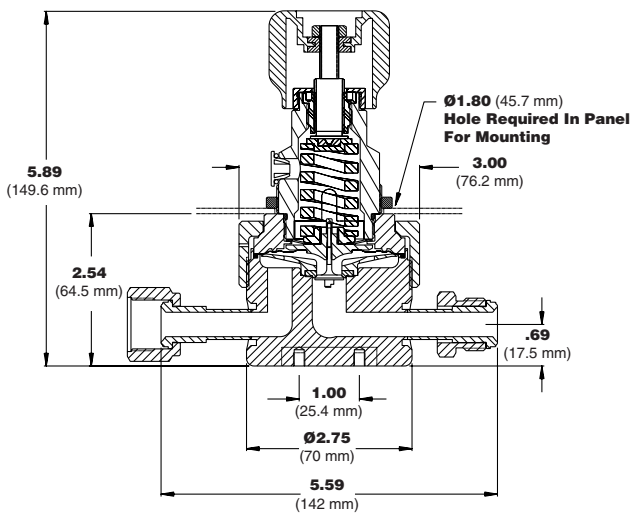

Flow Curves

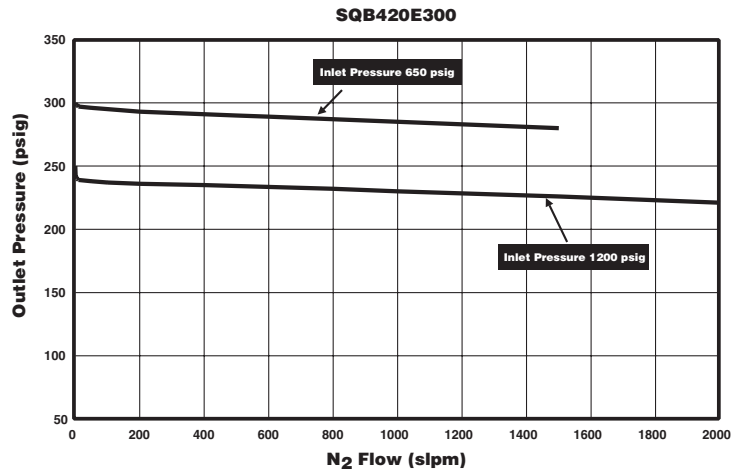

Porting Configurations

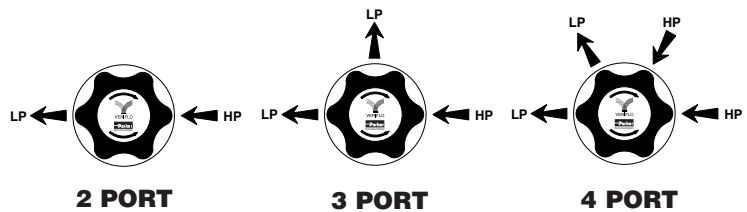

Ordering Information

SQB420E 100 4P 01 20 FS8 MMMF PM

BASIC SERIES
SQB420E

PRESSURE SETTING
100 = 5 to 100 psig
200 = 5 to 200 psig
300 = 5 to 300 psig

MATERIAL
= 316L Stainless Steel
H = Hastelloy C-22®

PORTING
2P = 2 Ports
3P = 3 Ports
4P = 4 Ports

OUTLET GAUGE
01 = 0 - 100 psig
2 = 0 - 200 psig
4 = 0 - 400 psig
X = No Gauge

OPTIONAL FEATURES
PM = Panel Mount
TH = Hastelloy C-22® Trim (Compression Member)
VESP = Vespel® Seat*
SS = Stainless Steel Internals**

PORT CONFIGURATION
M = Male
F = Female
I = Internal Female Face Seal (1/4" Only)

PORT STYLE
FS8 = 1/2 Inch Face Seal
FS12 = 3/4 Inch Face Seal
TS6 = 3/8 Inch Tube Stubs
TS8 = 1/2 Inch Tube Stubs
TS12 = 3/4 Inch Tube Stubs

INLET GAUGE
10 = 0 - 1000 psig
20 = 0 - 2000 psig
X = No Gauge

* Recommended for Nitrous Oxide (N₂O) Service
** Recommended for Carbon Monoxide (CO) or Nickel Carbonyl Ni(CO)₄ Service

Hastelloy C-22® is a registered trademark of Haynes International, Inc.
Vespel® is a registered trademark of DuPont Company.

SQ60

High Performance Point-Of-Use Regulator



Parker Hannifin Corporation's Veriflo Division presents the SQ60 which was developed in response to the need for high-performance point-of-use regulators for modern semiconductor manufacturing. It is a springless, threadless, point-of-use regulator designed for process gas cabinets for gas companies, equipment manufacturers, and end users.

The SQ60 provides precise control of the process gas pressure at or near the tool up to 5 slpm. The result is a stable flow and pressure to the mass flow controller.



features

- ▶ Standard Hastelloy C-22® Poppet and Diaphragm.
- ▶ Tied-diaphragm for added safety.
- ▶ "Hurricane" cleaning for "near absolute" contamination control.
- ▶ Capable of operating at a range of flows from 0.1 cc/min to 5 slpm.
- ▶ Metal-to-metal, diaphragm-to-body seal assures high leak integrity.
- ▶ No springs or threads are exposed to the wetted area.

materials of construction

Wetted

Body "VeriClean", Veriflo's high purity type 316L VAR Stainless Steel™, Hastelloy C-22®
 Seat PCTFE, optional Vespel®
 Diaphragm Hastelloy C-22®
 Poppet Hastelloy C-22®
 Compression Member "VeriClean", Veriflo's high purity type 316L Stainless Steel™, optional Hastelloy C-22®

Non-Wetted

Cap Brass, Nickel Plated
 Nut Brass, Nickel Plated
 Knob (Blue). ABS Plastic

operating conditions

Maximum inlet pressure 250 psig (17 barg)
 Outlet pressure 0-30 psig (2 barg)
 0-50 psig (3 barg), 0-100 psig (7 barg)
 Temperature -40°F to 150°F (-40°C to 66°C)

surface finishes

Standard Ra 10 micro inch (.25 micro meter) or less
 Optional Ra EV=5 micro inch (.13 micro meter) or less

functional performance

Design proof pressure 375 psig (26 barg)
 Design burst pressure 750 psig (52 barg)
 Flow capacity. C_v .054 (SEMI Flow Coefficient Test #F32-0998)

Design Leak Rate:

Across Seat 5 x 10⁻⁸ scc/sec He
 Inboard 2 x 10⁻¹⁰ scc/sec He
 Outboard 2 x 10⁻⁹ scc/sec He

internal volume

6.35 cc

standard connections

Any combination of FS male and/or female fittings:
 1/4" Gland to gland length 3.7 ± .02 in. (94 ± .5 mm)

1/4" tube stubs inlet and outlet available:
 End to end length. 3.7 ± .02 (94 ± .5 mm)

approximate weight

4 lbs 10 oz. (2.1 kgs)



SQ60

Dimensional Drawing

All dimensions are reference and nominal.

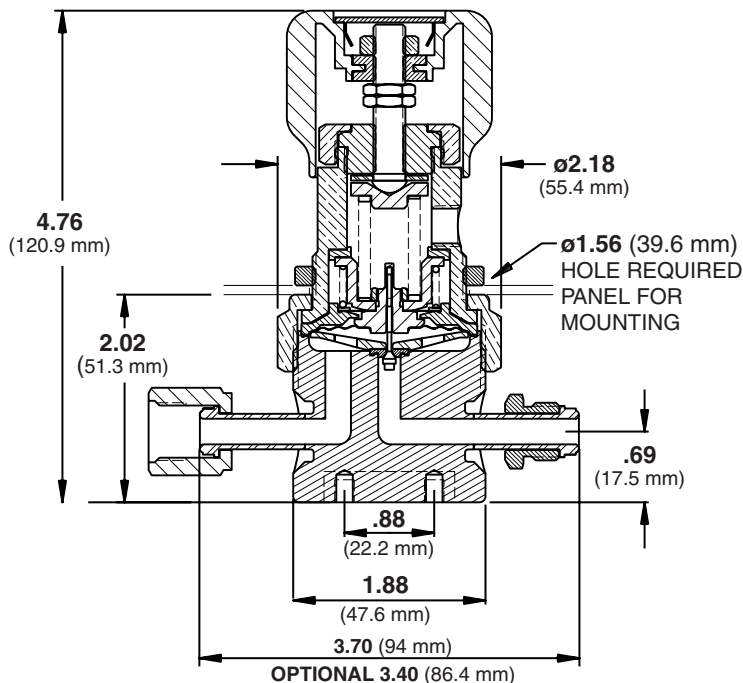

Flow Curves

Inlet Pressure: 30 psig

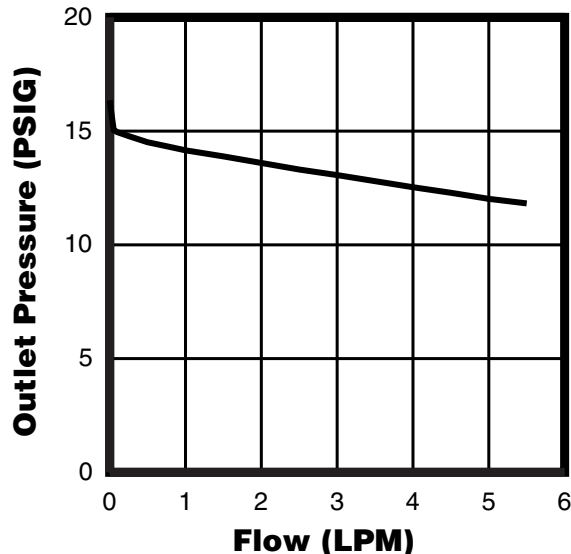

Porting Configurations

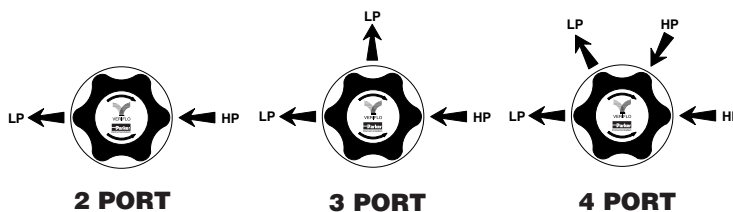

Ordering Information

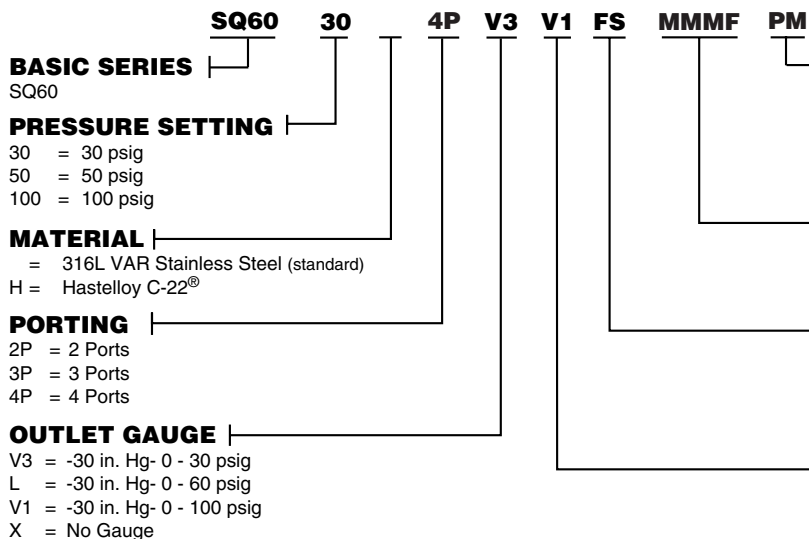

OPTIONAL FEATURES

- PM = Panel Mount
- SS = Stainless Steel Internals**
- TH = Hastelloy C-22[®] Trim (Compression Member)
- VESP = Vespe[®] Seat*
- 3.4 = 3.4" Optional End-To-End Dimension

PORT CONFIGURATION

- M = Male
- F = Female
- I = Internal Female Face Seal (1/4" Only)

PORT STYLE

- FS = 1/4" Face Seal
- FS8 = 1/2" Face Seal
- TS = 1/4" Tube Stubs
- TS6 = 3/8" Tube Stubs

INLET GAUGE

- V1 = -30 - 0 - 100 psig
- 2 = 0 - 200 psig
- 4 = 0 - 400 psig
- X = No Gauge

* Recommended for Nitrous Oxide (N₂O) Service

** Recommended for Carbon Monoxide (CO) or Nickel Carbonyl Ni(CO)₄ Service

Hastelloy C-22[®] is a registered trademark of Haynes International, Inc.
Vespe[®] is a registered trademark of DuPont Company.



SQ60SA

High Performance Point-Of-Use Regulator



Parker Hannifin Corporation's Veriflo Division presents the SQ60SA. This regulator was developed in response to the need for high performance point-of-use pressure regulator in the sub-atmospheric range. The SQ60SA was designed as a special modification of the popular SQ60, which revolutionized low flow point-of-use regulation.

Precise control of the gas pressure to the process tool makes stable process control by a mass flow controller possible. The resulting accurate delivery from the mass flow controller goes right to the bottom line in process repeatability.



features

- ▶ Sub-atmospheric pressure control.
- ▶ Fail safe seat with "tied-diaphragm" construction.
- ▶ Hurricane cleaning for "near-absolute" contamination control.
- ▶ Capable of operating at 5 scc/min up to 5 lpm.
- ▶ Design and materials of construction ensure compatibility with corrosive gases.
- ▶ Metal to metal seal to atmosphere.
- ▶ No wetted spring.
- ▶ Standard full internal electropolish.



materials of construction

Wetted

Body "VeriClean", Veriflo's high purity type 316L VAR Stainless Steel™, Hastelloy C-22®
Seat PCTFE, optional VespeI®
Diaphragm Hastelloy C-22®
Poppet Hastelloy C-22®
Compression Member "VeriClean", Veriflo's high purity type 316L Stainless Steel™, optional Hastelloy C-22®

Non-Wetted

Cap. Brass Nickel Plated
Nut. 316L Stainless Steel
Knob (White) ABS Plastic

operating conditions

Maximum Inlet pressure 250 psig (17 barg)
Outlet pressure -25 in Hg to 15 psig (1 barg)
Temperature -40°F to 150°F
(-40°C to 66°C)

surface finishes

Standard Ra 10 micro inch
(.25 micro meter) or less
Optional Ra EV=5 micro inch
(.13 micro meter) or less

functional performance

Design proof pressure 375 psig (26 barg)
Design burst pressure 750 psig (52 barg)
Flow Capacity Cv 0.15
(SEMI Flow Coefficient Test #F-32-0998)

Design Leak Rate:

Across Seat 5×10^{-8} cc/sec He
Inboard 2×10^{-10} cc/sec He
Outboard 2×10^{-9} cc/sec He

internal volume

6.35 cc

standard connections

Any combination of FS male and/or female fittings.
1/4 inch Gland to gland length. $3.70 \pm .02$ in.
(94 ± .05 mm)
1/4 inch tube stubs inlet and outlet available.
End to end length $3.70 \pm .02$ in.
(94 ± .05 mm)

approximate weight

1.5 lbs (7kgs)

SQ60SA

Dimensional Drawing

All dimensions are reference and nominal.

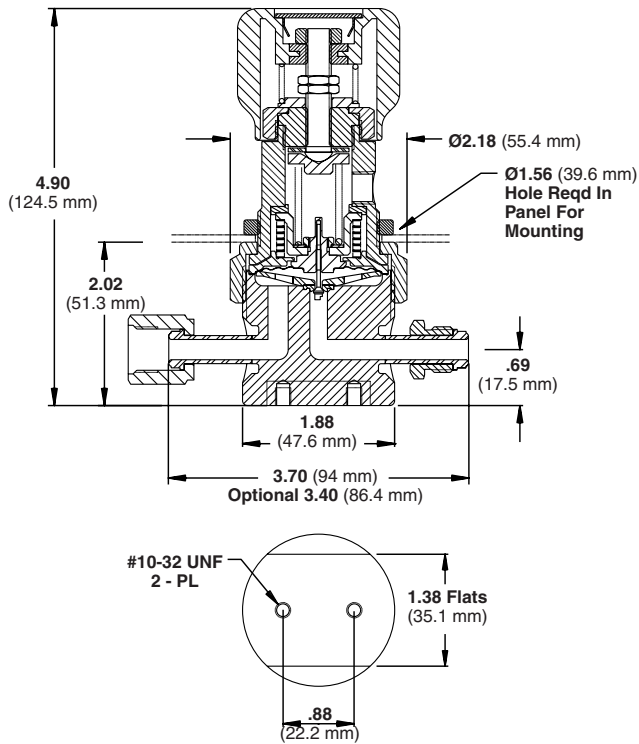

Flow Curves

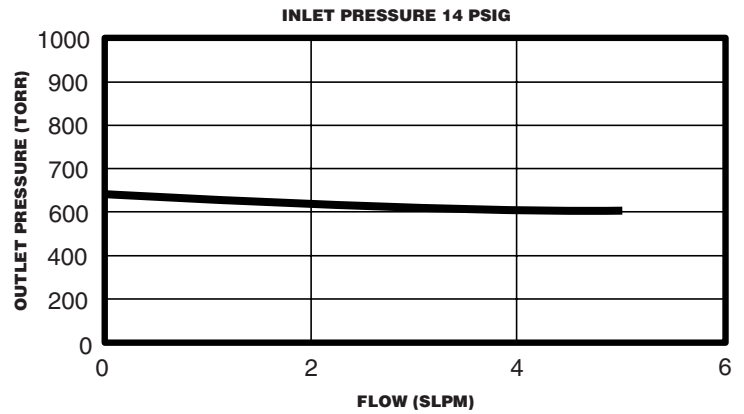

Porting Configurations

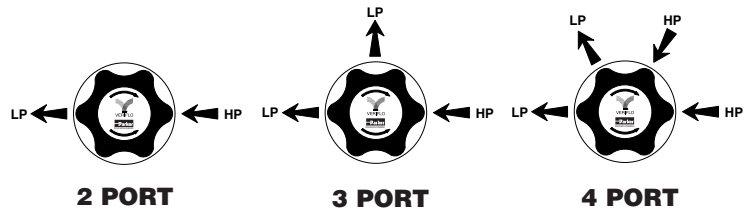

Ordering Information

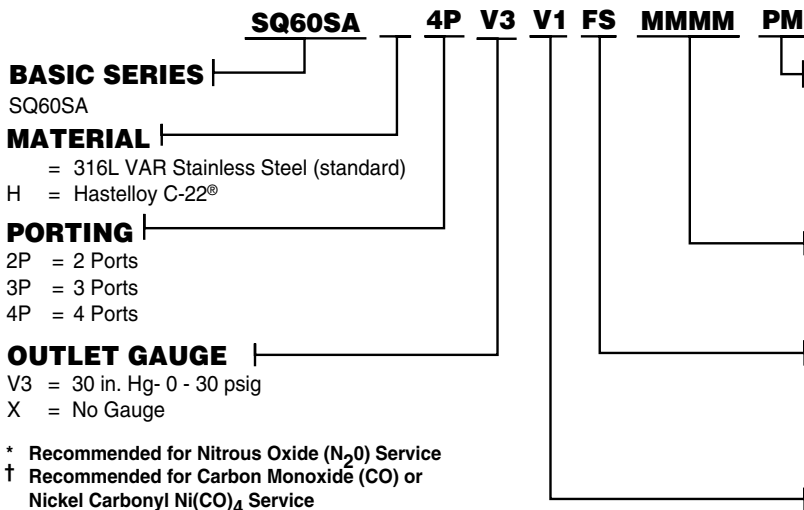

* Recommended for Nitrous Oxide (N₂O) Service
 † Recommended for Carbon Monoxide (CO) or Nickel Carbonyl Ni(CO)₄ Service

Hastelloy C-22[®] is a registered trademark of Haynes International, Inc.
 Vespel[®] is a registered trademark of DuPont Company.

OPTIONAL FEATURES

- PM = Panel Mount
- SS = Stainless Steel Internals †
- TH = Hastelloy C-22[®] Trim (Compression Member)
- VESP = Vespel[®] Seat*
- 3.4 = 3.4" Optional End-To-End Dimension

PORT CONFIGURATION

- M = Male
- F = Female
- I = Internal Face Seal Female (1/4" Only)

PORT STYLE

- FS = 1/4" Face Seal
- FS8 = 1/2" Face Seal
- TS = 1/4" Tube Stub
- TS6 = 3/8" Tube Stub

INLET GAUGE

- L = 30 in. Hg- 0 - 60 psig
- V1 = 30 in. Hg- 0 - 100 psig
- X = No Gauge





Parker Hannifin Corporation's Veriflo Division presents the SQHP. This high purity regulator is a continuation of Veriflo's process-proven SQ line of regulators. A high pressure version of the high-purity SQ60 point-of-use regulator, the SQHP was designed for state-of-the-art semiconductor applications.



features

- Standard Hastelloy C-22[®] Poppet and Diaphragm.
- ▶ "VeriClean", Veriflo's low sulfur high purity 316L VAR Stainless Steel™, which enhances electropolishing, surface resistance, and corrosion resistance.
- ▶ Provides precise pressure control of outlet pressure with an inlet pressure as high as 3,500 psig.
- ▶ No high pressure seals to atmosphere.
- ▶ Unique patented compression member loads the seal to the body without requiring a threaded nozzle or additional seals to atmosphere.
- ▶ Tied diaphragm for added safety.
- ▶ Metal-to-metal diaphragm-to-body seal assures high leak integrity.
- ▶ 100% Helium leak tested.



materials of construction

Wetted

Body "VeriClean", Veriflo's high purity . type 316L VAR Stainless Steel™, Hastelloy C-22[®]
 Seat PCTFE, optional Vespel[®]
 Diaphragm Hastelloy C-22[®]
 Poppet Hastelloy C-22[®]
 Compression Member "VeriClean", Veriflo's high purity type 316L VAR Stainless Steel™, optional Hastelloy C-22[®]

Non-Wetted

Nut 316L Stainless Steel
 Cap Nickel Plated Brass
 Knob (Red) ABS Plastic

operating conditions

Maximum inlet pressure . . . 3500 psig (240 barg)
 Outlet pressure 0 to 30 psig (2 barg)
 0 to 60 psig (4 barg), 0 to 100 psig (7 barg)
 Temperature -40°F to 150°F (-40°C to 66°C)

surface finishes

Standard Ra 10 micro inch
 (.25 micro meter) or less
 Optional Ra EV=5 micro inch
 (.13 micro meter) or less

functional performance

Design proof pressure 5,250 psig (362 barg)
 Design burst pressure 10,500 psig (724 barg)
 Flow capacity C_v .06
 (SEMI Flow Coefficient Test #F-32-0998)

Design Leak Rate:

Outboard 2 x 10⁻⁹ scc/sec He
 Inboard 2 x 10⁻¹⁰ scc/sec He
 Across seat 5 x 10⁻⁸ scc/sec He
 Supply pressure effect. . . . <0.1 psig per 100 psig
 (<.02 barg per 6.7 barg)

internal volume

6.35 cc

standard connections

Any combination of FS male and/or female fittings.
 1/4" Gland to gland length 3.70 ± .02 in.
 (94.0 ± .05 mm)
 1/4" inch tube stubs inlet and outlet.
 End to end length 3.70 ± .02 in.
 (94.0 ± .05 mm)

approximate weight

1.5 lbs (7kgs)

SQHP

Dimensional Drawing

All dimensions are reference and nominal.

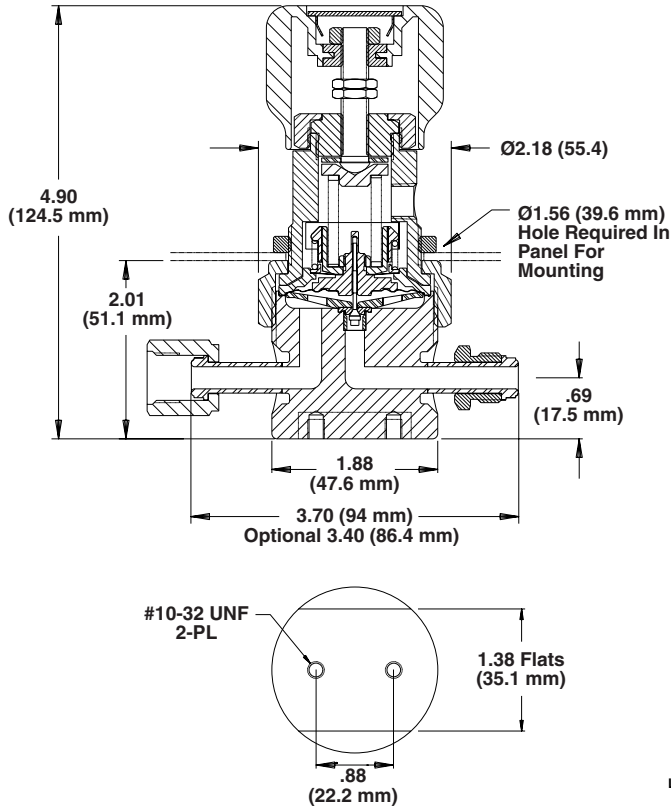

Flow Curves

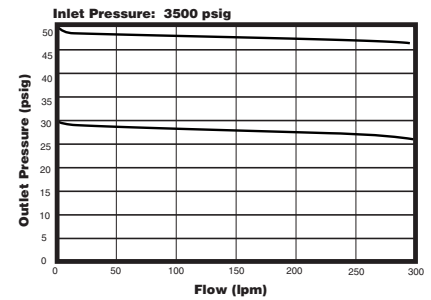
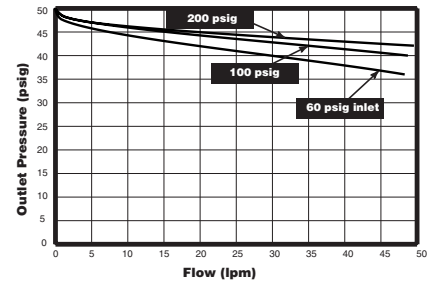

Porting Configurations

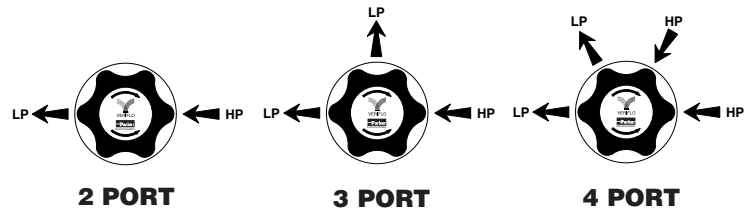

Ordering Information

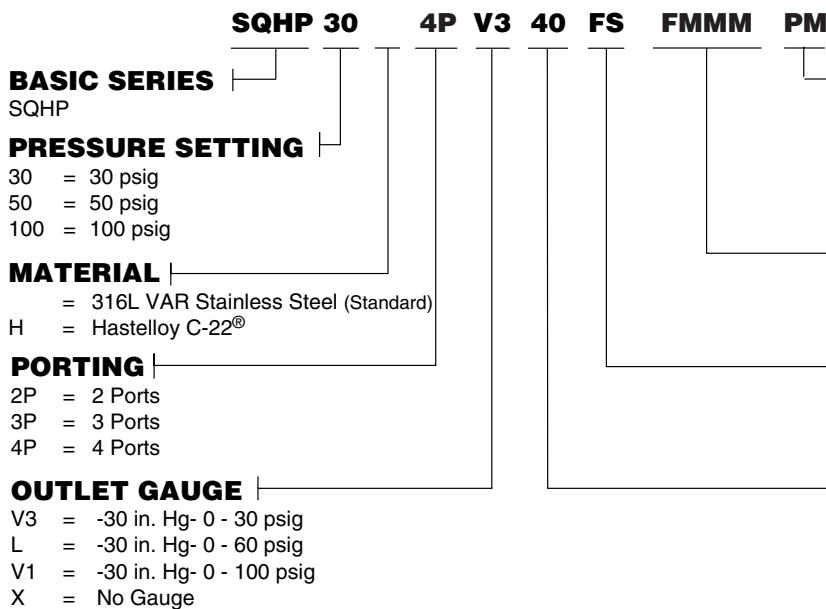

OPTIONAL FEATURES

- PM = Panel Mount
- SS = Stainless Steel Internals**
- TH = Hastelloy C-22® Trim (Compression Member)
- VESP = Vespel® Seat*
- 3.4 = 3.4" Optional End-To-End Dimension

PORT CONFIGURATION

- M = Male
- F = Female
- I = Internal Female Face Seal (1/4" Only)

PORT STYLE

- FS = 1/4" Face Seal
- TS = 1/4" Tube Stubs
- TS6 = 3/8" Tube Stubs

INLET GAUGE

- 10 = 0 - 1000 psig
- 30 = 0 - 3000 psig
- 40 = 0 - 4000 psig
- X = No Gauge

* Recommended for Nitrous Oxide (N₂O) Service

** Recommended for Carbon Monoxide (CO) or Nickel Carbonyl Ni(CO)₄ Service

Hastelloy C-22® is a registered trademark of Haynes International, Inc.
Vespel® is a registered trademark of DuPont Company.





Parker Hannifin Corporation's Veriflo Division presents the Quantum 959. The 959 is a high purity, high pressure tied diaphragm regulator.

The 959 regulator controls pressure flows accurately and predictably without changing the liquids or gases and without adding particles or ions to the flowing material.

Subatmospheric pressure control available with the NPR959.



features

- ▶ "VeriClean", Veriflo's low sulfur high purity 316L, Stainless Steel™ enhances electropolishing, welding, and corrosion resistance.
- ▶ Unique patented compression member loads the seal to the body without requiring a threaded nozzle or additional seals to atmosphere.
- ▶ Internally threadless nozzle assembly.
- ▶ Metal-to-metal diaphragm-to-body seal assures high leak integrity.
- ▶ Minimal particle generation and entrapment.
- ▶ High cycle life.
- ▶ 100% Helium leak tested.

materials of construction

Wetted

- Body "VeriClean", Veriflo's high purity type 316L Stainless Steel™, Hastelloy C-22®
- Seat PCTFE, optional Vespel®
- Diaphragm 316L Stainless Steel, Hastelloy C-22®
- Poppet 316L Stainless Steel, Hastelloy C-22®
- Poppet Spring 316L Stainless Steel, Inconel®
- Compression Member 316L Stainless Steel™, Hastelloy C-22®
- Screen Hastelloy C-22®

Non-Wetted

- Nut 316L Stainless Steel
- Cap Nickel Plated Brass

Knob:

- 959 (Black) ABS Plastic
- NPR959 (White) ABS Plastic

operating conditions

- Maximum inlet 3500 psig (240 barg)
- .2 C_v 1200 psig (83 barg)
- Outlet 0-30 psig (2 barg)
0-100 psig (7 barg), 0-150 psig (10.3 barg)
- NPR -25 in Hg to 30 psig
- Temperature -40°F to 150°F (-40°C to 65°C)

functional performance

- Flow capacity C_v = .04
optional C_v = .20
(SEMI Flow Coefficient Test # F-32-0998)

Design Leak Rate:

- Outboard 1 x 10⁻⁹ scc/sec He
- Inboard 2 x 10⁻¹⁰ scc/sec He
- Across seat 2 x 10⁻⁹ scc/sec He

standard configurations

- Any combination of FS male and/or female fittings:
- 1/4 inch Gland to gland length . . . 3.70 ± .02 in.
(94.0 ± .5 mm)
- Optional 3.40 ± .02 in. (86.0 ± .5 mm)
- 1/4 inch tube stubs inlet and outlet:
- End to end length . . 3.70 ± .02 in. (94.0 ± .5 mm)
- 1/4 inch female pipe threads inlet and outlet:
- End to end length . . 1.88 ± .02 in. (47.7 ± .5 mm)

internal volume

5.41 cc

surface finishes

- Standard Ra 15-20 m inch
(.38 to .5 m meter) or less
- Optional Ra EX = 10 m inch (.25 m meter)
EV = 5 m inch (.13 to .5 m meter) or less

approximate weight

2 lbs (.9 kg)



Dimensional Drawing

All dimensions are reference and nominal.

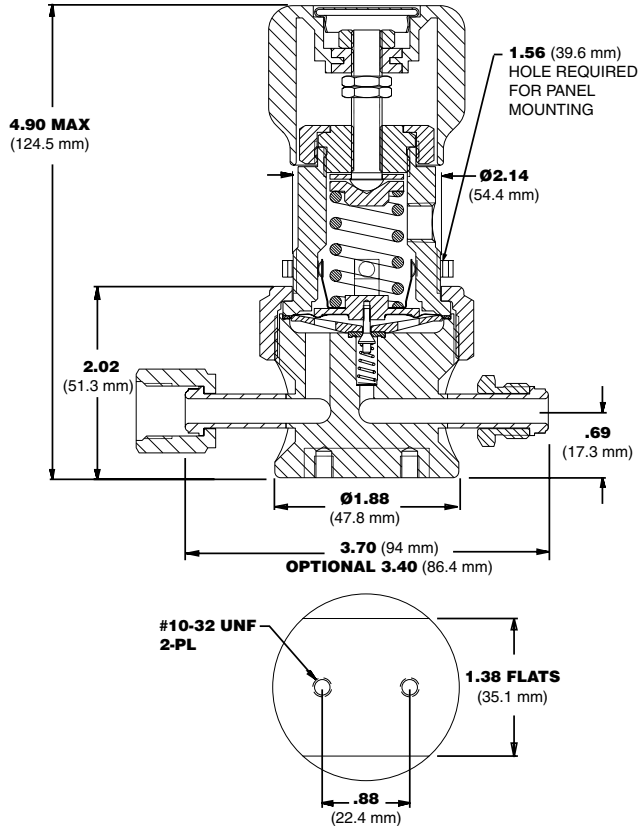

Flow Curves

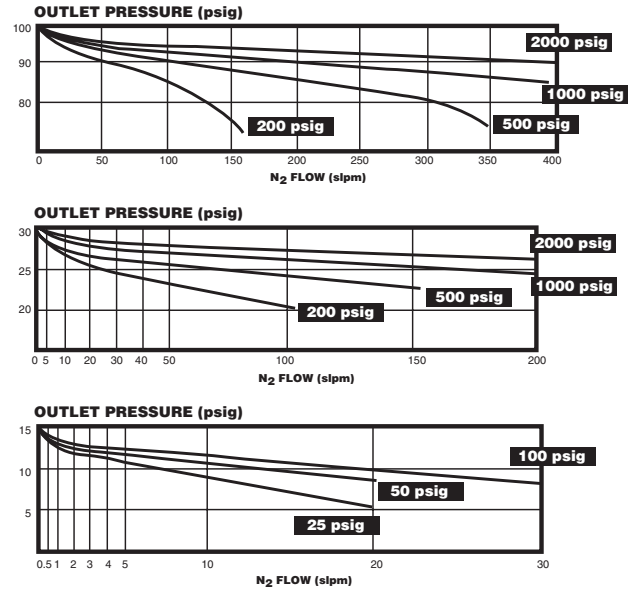

Porting Configurations

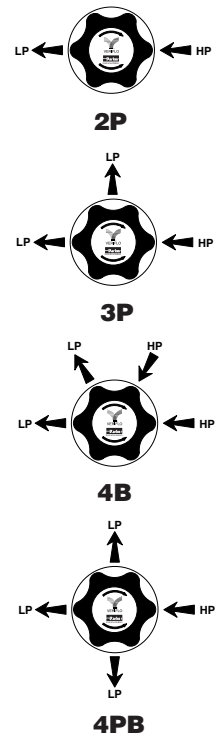

Ordering Information

95930 W 4P V3 10 FS MMMM PM

BASIC SERIES

95930 = 0 - 30 psig
 959100 = 0 - 100 psig
 959150 = 0 - 150 psig
 NPR95930 = -25 in Hg- 0-30 psig

MATERIALS

W = Welded 316L Stainless Steel
 H = Hastelloy C-22®*

PORTING

2P = 2 Ports
 3P = 3 Ports
 4P = 4 Ports
 4PB = 4 Ports

OUTLET GAUGE

V3 = -30 in Hg-0-30 psig
 V1 = -30 in Hg-0-100 psig
 V2 = -30 in Hg-0-200 psig
 X = No Gauge

OPTIONAL FEATURES

DO = Dome Loaded
 PM = Panel Mount
 TH = Trim Hastelloy C-22® Internals**
 VESP = Vespel® Seat
 (Recommended for Nitrous Oxide-N₂O Serviced)
 2 = 0.2 Cv
 3.4 = FS Fittings 3.4" Face to Face

PORT CONFIGURATION

M = Male
 F = Female
 I = Internal Face Seal***

PORT STYLE

FS = 1/4" Face Seal
 TS = 1/4" Tube Stubs

INLET GAUGE

V1 = -30 in Hg -0-100 psig
 10 = 0-1000 psig
 30 = 0-3000 psig
 40 = 0-4000 psig
 X = No Gauge

* Hastelloy C-22® Material Includes: Hastelloy C-22® Body, Compression Member, Poppet, Diaphragm, Screen, and Inconel® Spring

** Trim Hastelloy C-22® Includes: 316L Stainless Steel Body, Hastelloy C-22® Compression Member, Poppet, Diaphragm, Screen, and Inconel® Spring

*** Use Material Code 'W'

Hastelloy® C-22 is a registered trademark of Haynes International, Inc.

Vespel® is a registered trademark of DuPont Company.

Inconel® is a registered trademark of Inco Alloys International

Dimensional Drawing

All dimensions are reference and nominal.

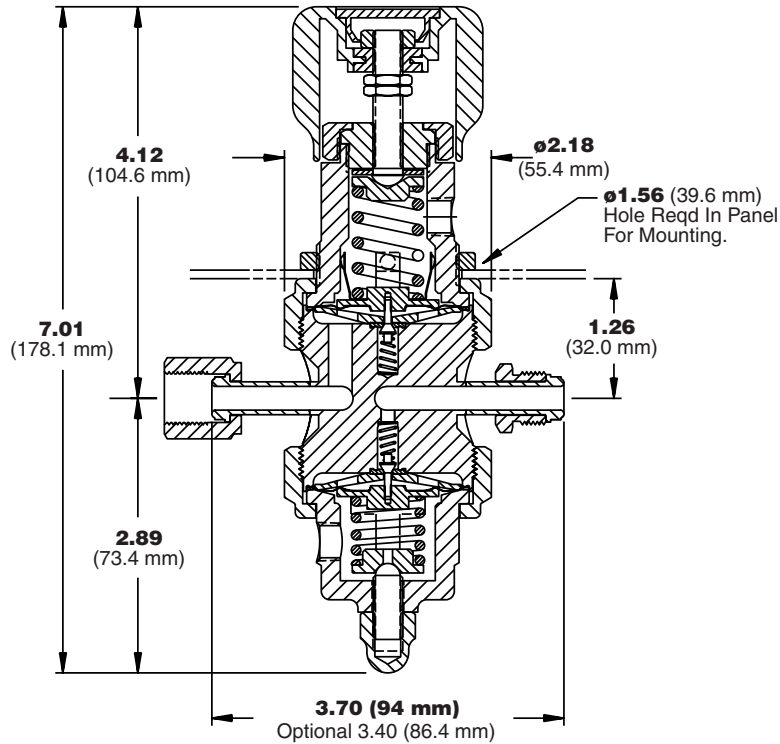

Flow Curves

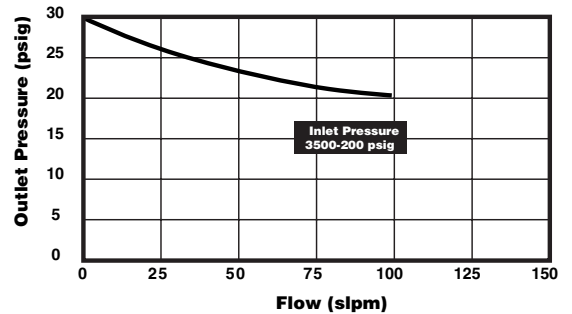
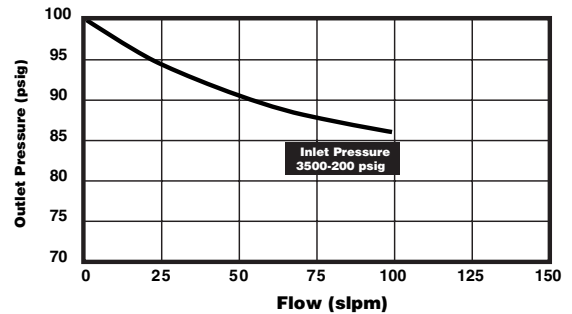

These tests were performed using Nitrogen at ambient conditions.

Ordering Information

73530 W 4P V3 10 FS MMMM PM

BASIC SERIES

73530 = 0-30 psig
735100 = 0-100 psig
NPR73530 = -25 in Hg-0-30 psig

MATERIALS

W = Welded 316L Stainless Steel
H = Hastelloy C-22® *

PORTING

2P = 2 Ports
3P = 3 Ports
4P = 4 Ports
5P = 5 Ports
7P = 7 Ports

REGULATOR OUTLET GAUGE

V3 = -30 in Hg-0-30 psig
L = -30 in Hg-0-60 psig
V1 = -30 in Hg-0-100 psig
X = No Gauge

* Includes body, diaphragm, compression member, poppet, and spring.

** Includes diaphragm compression member, poppet, and spring.

Hastelloy® C-22 is a registered trademark of Haynes International, Inc.

VespeI® is a registered trademark of DuPont Company.

Inconel® is a registered trademark of Inco Alloys International

OPTIONAL FEATURES

PM = Panel Mount
TH = Hastelloy C-22® Trim**
VESP = VespeI® Seat
(Recommended for Nitrous Oxide - N₂O Serviced)
3.4 = FS Fittings 3.4" Face to Face

PORT CONFIGURATION

M = Male
F = Female
I = Internal Female Face Seal

PORT STYLE

FS = 1/4" Face Seal
TS = Tube Stubs

REGULATOR INLET GAUGE

10 = 0-1000 psig
20 = 0-2000 psig
30 = 0-3000 psig
40 = 0-4000 psig
X = No Gauge

Porting Configurations

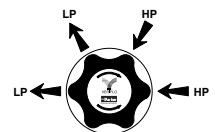

Porting Code 4P

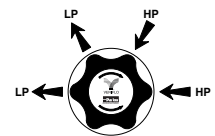

Porting Code 5P

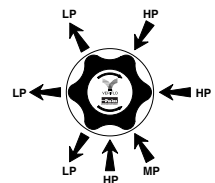

Porting Code 7P

QR4000

High Pressure Non-Tied Diaphragm Regulator



Parker Hannifin Corporation's Veriflo Division presents the QR4000 Series pressure regulator. The QR4000 is a high purity, high pressure non-tied diaphragm regulator. The QR4000 Series utilizes a metal-to-metal diaphragm seal which provides enhanced leak integrity.



features

- ▶ "VeriClean", Veriflo's custom low sulfur, high purity 316L Stainless Steel™ that enhances electropolishing, welding and corrosion resistance.
- ▶ Unique patented compression member loads the seal to the body without requiring a threaded nozzle or additional seals to atmosphere.
- ▶ Internally threadless nozzle assembly.
- ▶ Metal-to-metal diaphragm to body seal assures high leak integrity and life-time bonding.
- ▶ Minimal particle generation and entrapment.
- ▶ High cycle life.
- ▶ 100% Helium leak tested.

materials of construction

Wetted

Body "VeriClean", Veriflo's high purity type 316L, Stainless Steel™, Hastelloy C-22®
 Compression Member Inconel®
 Diaphragm Hastelloy C-22®
 Poppet Elgiloy®
 Poppet Spring Inconel®
 Screen Hastelloy C-22®
 Carrier Stainless Steel*, Hastelloy C-22®
 Backup Washer 316 Stainless Steel™
 Seat PCTFE, PEEK™, Vespel®

Non-Wetted

Nut 316L Stainless Steel™
 Cap Nickel Plated Brass, optional Stainless Steel
 Knob (Black) ABS Plastic

operating conditions

Maximum inlet 4000 psig (276 barg)
 Outlet . . 1-10 psig† (.7 barg), 1-30 psig (2 barg),
 1-60 psig (4 barg), 2-100 psig (7 barg),
 2-250 psig (17 barg), 20-500 psig (35 barg)

Temperature:

PCTFE -40°F to 150°F (-40°C to 65°C)
 PEEK™ -40°F to 275°F (-40°C to 135°C)
 Vespel® -40°F to 500°F (-40°C to 260°C)

functional performance

Flow capacity:

Standard C_v .06
 Optional C_v .02, .15†
 (SEMI Flow Coefficient Test #F-32-0998)

Design Leak Rate:

Outboard 1 x 10⁻⁹ scc/sec He
 Inboard 2 x 10⁻¹⁰ scc/sec He
 Across seat 4 x 10⁻⁸ scc/sec He

Supply Pressure Effect:

.02 C_v 0.23 psig per 100 psig
 (.016 barg per 7 barg)
 .06 C_v 0.6 psig per 100 psig
 (.04 barg per 7 barg)
 .15 C_v 1.5 psig per 100 psig
 (.1 barg per 7 barg)

standard configurations

See Dimension Table on back page.

internal volume

4.0 cc without fittings

surface finishes

Standard Ra 10 Micro Inch
 (.25 micro meter) or less
 Optional Ra 5 Macro Inch
 (.13 micro meter) or less

approximate weight

1.5 lbs (.7 kg)

* Proprietary Carpenter Stainless Steel

† Refer to Range Table for specific information.



QR4000

Dimensional Drawing

All dimensions are reference and nominal.

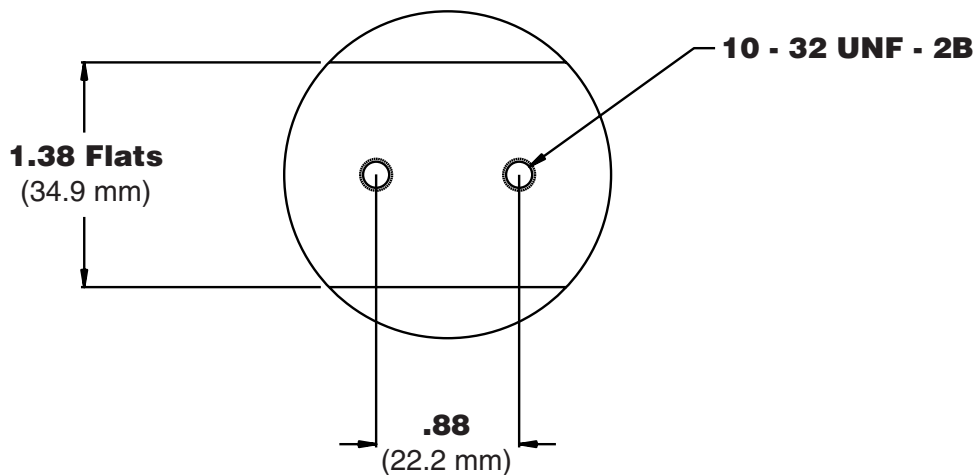
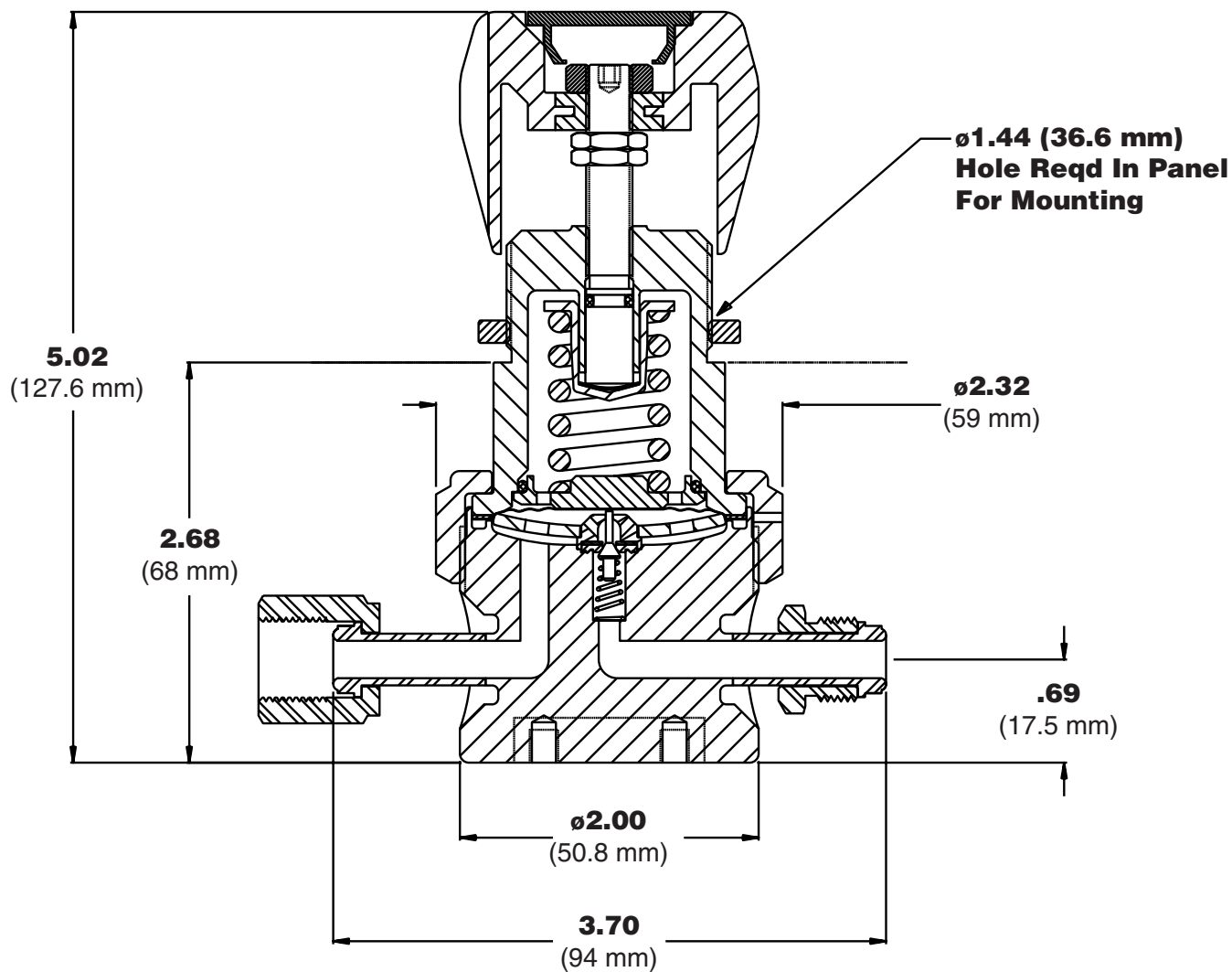

QR4000

Flow Curve

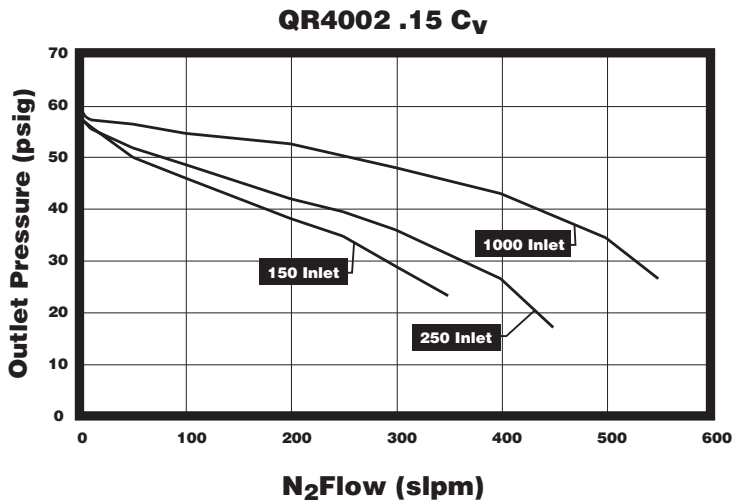
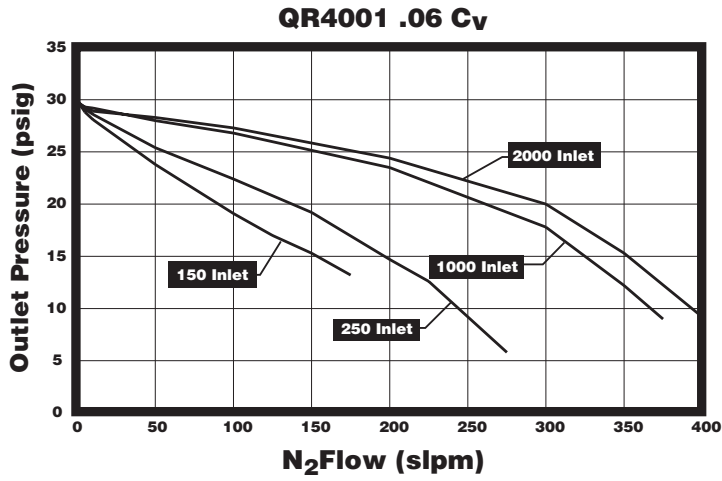

Porting Configurations

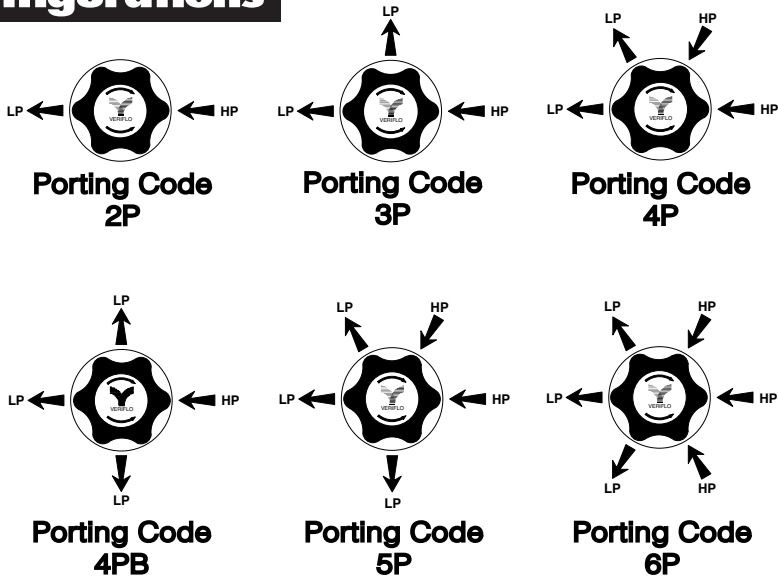

QR4000

Ordering Information

QR4003 S K 4P 01 40 FS MMMM D

BASIC SERIES

QR4000= 1 - 10 psig†
 QR4001= 1 - 30 psig
 QR4002= 1 - 60 psig
 QR4003= 2 - 100 psig
 QR4004= 3 - 250 psig
 QR4005= 20 - 500 psig

MATERIALS

H = Hastelloy C-22®*
 S = 316L Stainless Steel

FLOW CAPACITY†

= .06 Cv (standard)
 1 = .02 Cv
 2 = .15 Cv

SEAT MATERIALS

K = PCTFE (formerly Kel-F 81®)
 P = PEEK™
 V = Vespel®**

PORTING

2P = 2 Ports
 3P = 3 Ports
 4P = 4 Ports
 4PB = 4 Ports
 5P = 5 Ports
 6P = 6 Ports

OUTLET GAUGE

OL = 0 - 60 psig
 01 = 0 - 100 psig
 4 = 0 - 400 psig
 6 = 0 - 600 psig
 X = No Gauge

OPTIONAL FEATURES

D = Dome Loaded

Note: PANEL MOUNT OPTION:

Order Panel Nut Ring P/N 41900363
 as separate line item.

PORT CONFIGURATION

M = Male
 F = Female
 I = 1/4" Internal Face Seal Female

PORT STYLE

FS = 1/4" Face Seal
 FS8 = 1/2" Face Seal
 TS = 1/4" Tube Stub
 S6 = 3/8" Tube Stub
 TS8 = 1/2" Tube Stub

INLET GAUGE

01 = 0 - 100 psig
 10 = 0 - 1000 psig
 20 = 0 - 2000 psig
 30 = 0 - 3000 psig
 40 = 0 - 4000 psig
 X = No Gauge

* Hastelloy C-22® material includes: Hastelloy C-22® body, Hastelloy C-22® Carrier

** Recommended for Nitrous Oxide (N₂O) Service

† Refer to Range Table for specific information

†† Only available with .06 Cv

Hastelloy C-22® is a registered trademark of Haynes International, Inc.

Inconel® is a registered trademarks of Inco Alloys International.

Elgiloy® is a registered trademark of Elgiloy Company.

Vespel® is a registered trademark of DuPont Company.

Viton® is a registered trademark of DuPont Dow Elastomers.

PEEK™ is a trademark of Victrex plc.

Dimension Table

Connection Type	End to End Dimension
1/4" Face Seal	3.70 ± .02 in. (94 ± .5 mm)
1/2" Face Seal	4.82 ± .02 in. (122.4 ± .5 mm)
All Tube Stubs	3.70 ± .02 in. (94 ± .5 mm)

Range Table

Model Basic Series	Max Inlet PSIG		
	C _v		
	.06	.02	.15
QR4000	400	400	400
QR4001	4000	4000	1250
QR4002	4000	4000	1250
QR4003	4000	4000	1250
QR4004	4000	4000	1250
QR4005	4000	4000	1250

NPR4000 Series

Welded Negative Pressure Regulator



Parker Hannifin Corporation's Veriflo Division presents the High Purity NPR4000 regulator for applications involving negative delivery pressures with low pressure gas sources.

This regulator is specifically designed to regulate negative pressures down to -26 in Hg vacuum (100 Torr). Typical applications include the delivery of low pressure gases from liquid sources such as WF₆, BCl₃.



features

- ▶ "VeriClean", Veriflo's custom low sulfur high purity 316L Stainless Steel™ that enhances electropolishing, welding and corrosion resistance.
- ▶ Consistently maintains outlet set point.
- ▶ Fluid media: corrosive and non-corrosive gases.
- ▶ Low internal volume.
- ▶ Positive upward and downward diaphragm stops.

materials of construction

Wetted

Body "VeriClean", Veriflo's high purity type 316L Stainless Steel, Hastelloy C-22®
 Compression Member Inconel®
 Diaphragm Hastelloy C-22®
 Pin Hastelloy C-22®
 Poppet Elgiloy®
 Poppet Spring 316L Stainless Steel, Hastelloy C-22®
 Screen Hastelloy C-22®
 Carrier Stainless Steel*, Hastelloy C-22®
 Seat PCTFE, PEEK™, Vespel®

Non-Wetted

Cap Nickel Plated Brass
 Nut 316L Stainless Steel, Nickel Plated Brass††
 Knob(White) ABS Plastic

operating conditions

Maximum inlet pressure 250 psig (17 barg)
 Outlet pressure 100 torr to 10 psig (-26 in Hg to .7 barg)

Temperature:

PCTFE -40°F to 150°F (-40°C to 66°C)
 PEEK™ -40°F to 275°F (-40°C to 135°C)
 Vespel® -40°F to 500°F (-40°C to 260°C)

functional performance

Flow capacity:

Standard C_v .06
 Optional C_v .02, .15
 (SEMI Flow Coefficient Test #F-32-0998)

Design Leak Rate:

Outboard 1 x 10⁻⁹ scc/sec He
 Inboard 2 x 10⁻¹⁰ scc/sec He
 Across seat 4 x 10⁻⁸ scc/sec He

Supply Pressure Effect06 psig (.04 barg) per 100 psig(6.80 barg)

standard configurations

Any configuration of 1/4" FS male and/or female fittings:
 Gland to gland length 3.70± .02 in. (94.0 ± .5 mm)
 See Porting Guide for available configurations.

internal volume

4.0 cc

surface finishes

Standard Ra . . . 10 micro inch (.25 micro meter)

approximate weight

1.5 lbs. (.7 kg)

* Proprietary Carpenter Stainless Steel with corrosion resistance equal or better than 316.

†† Nickel Plated Brass for PCTFE seat.



NPR4000 Series

Cross Sectional Drawing

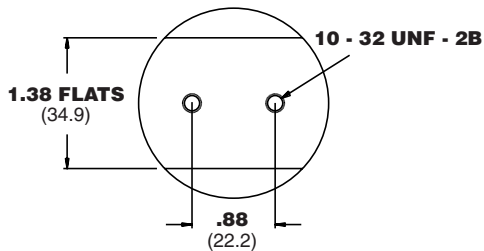
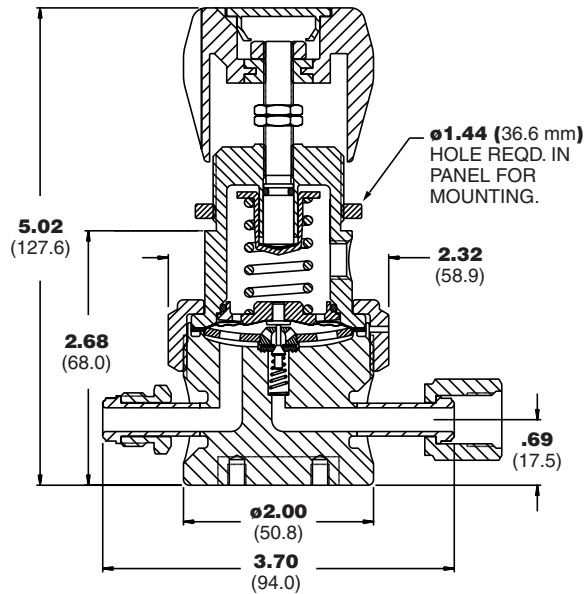

Flow Curves

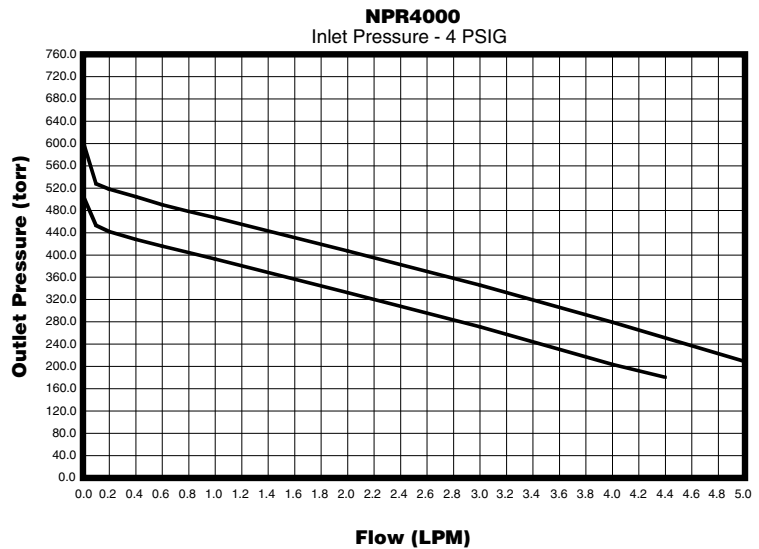

Porting Configurations

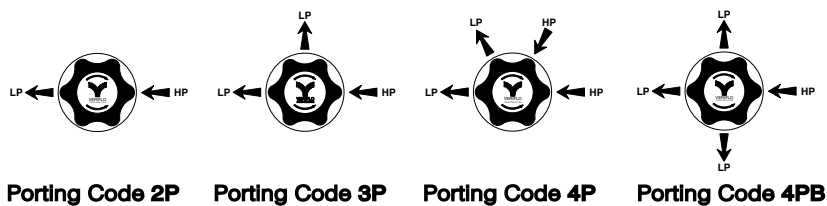

Ordering Information

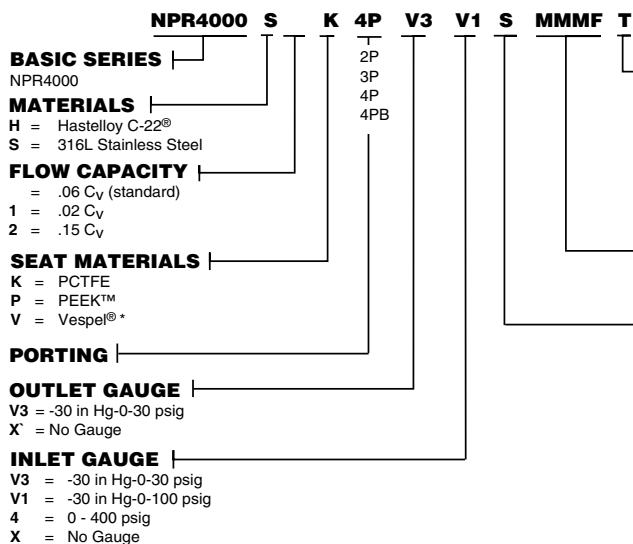

Note: PANEL MOUNT RING:
Order Panel Nut Ring
P/N 41900363 as separate
line item.

NOTES:
Gauge Ports are 1/4" FS Male standard.
Gauge Ports are 1/4" NPT Female for compression ends.

* Recommended for Nitrous Oxide (N₂O) Service

Hastelloy C-22® is a registered trademark of Haynes International, Inc.
Inconel® is a registered trademark of Inco Alloys International.
Elgiloy® is a registered trademark of Elgiloy Company.
Vespel® is a registered trademark of DuPont Company.
PEEK™ is a trademark of Victrex plc.



HFR900W Series

Cross Sectional Drawing

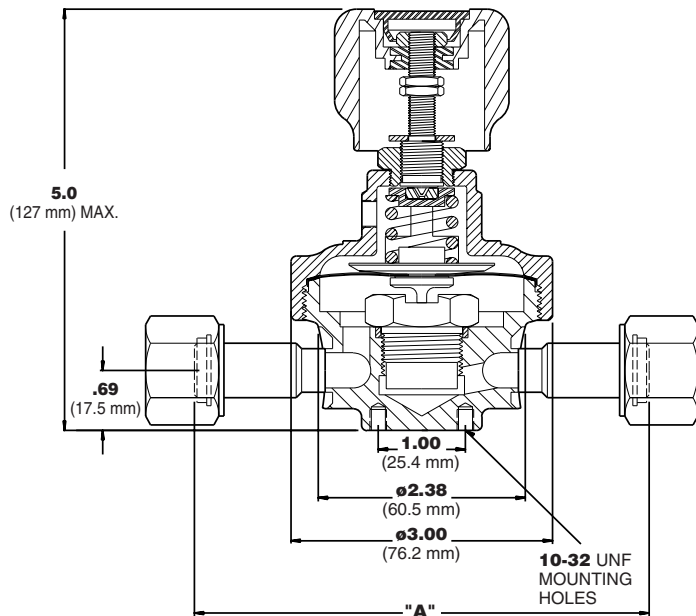

Flow Curves

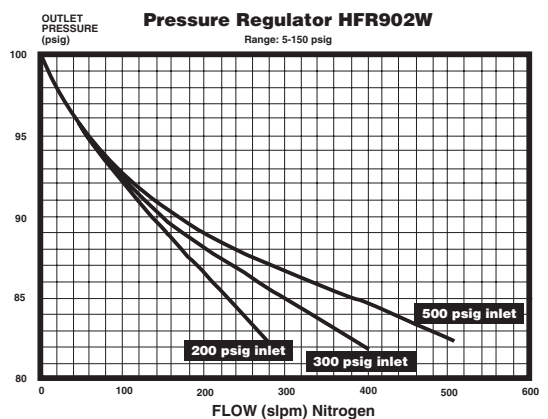
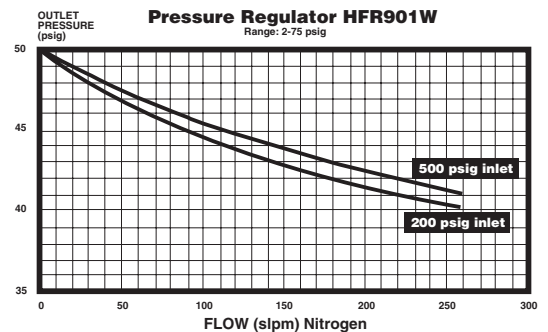
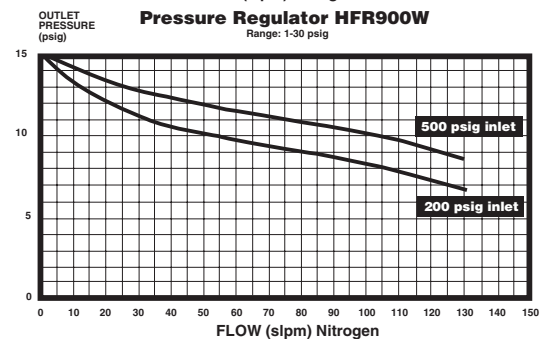
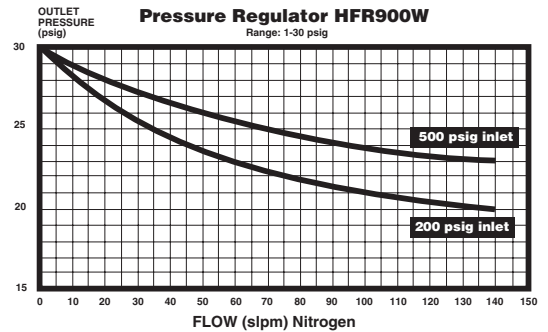

Connection Chart

Connection Size inlet & outlet	"A"	
	inch	mm
1/4" TS	3.76	95.50
3/8" TS	5.00	127.00
1/2" TS	5.00	127.00
1/4" FS	4.30	109.00
1/2" FS	5.20	133.00
1/2" Compression Fittings	4.78	121.40

Ordering Information

HFR900 W 4P 03 6 FS8 FMMF V PM

BASIC SERIES

HFR900 = 1-30 psig
HFR901 = 2-75 psig
HFR902 = 5-150 psig

MATERIALS

W = Welded 316L Stainless Steel

PORTING

2P = 2 Ports
3P = 3 Ports
4P = 4 Ports
4PB = 4 Ports

REGULATOR OUTLET GAUGE

03 = 0-30 psig
01 = 0-100 psig
2 = 0-200 psig
X = No Gauge

* Compression fittings are welded and inclusive of nuts and ferrules.

Viton® is a registered trademark of DuPont Dow Elastomers.
Kalrez® and Teflon® are registered trademarks of DuPont Company.

OPTIONAL FEATURES

PM = Panel Mount
R = Relief Valve

SEAL MATERIAL

K = Kalrez® (200 psig max)
V = Viton® (500 psig max)

PORT CONFIGURATION

M = Male
F = Female
I = Internal Face Seal
(1/4" Gauge Port Only)

PORT STYLE

FS = 1/4" Face Seal
FS8 = 1/2" Face Seal
TS = 1/4" Tube Stub
TS6 = 3/8" Tube Stub
TS8 = 1/2" Tube Stub
8T = 1/2" Compression Fittings*

REGULATOR INLET GAUGE

4 = 0-400 psig
6 = 0-600 psig
X = No Gauge

Parker
Instrumentation

SPR860 Series

Dimensional Drawing

All dimensions are reference and nominal.

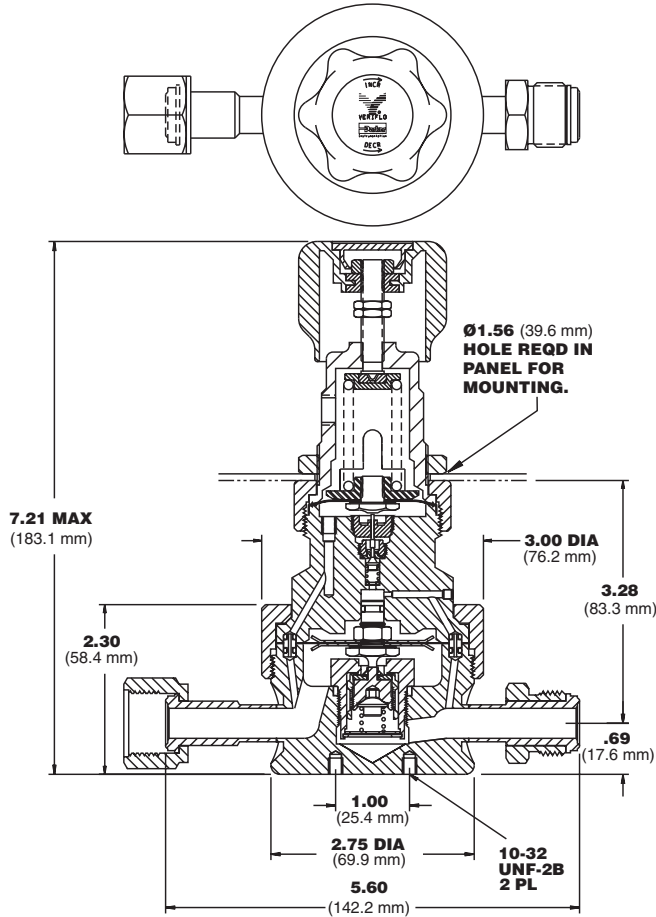

Flow Curves

SPR860
Range: 0-30 psig

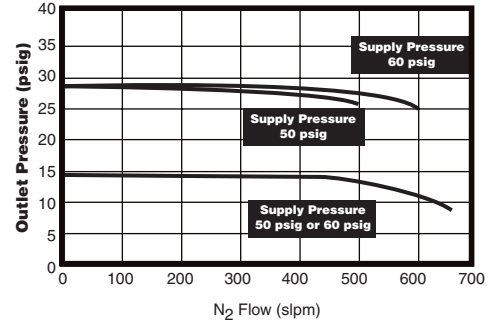

SPR861
Range: 0-100 psig

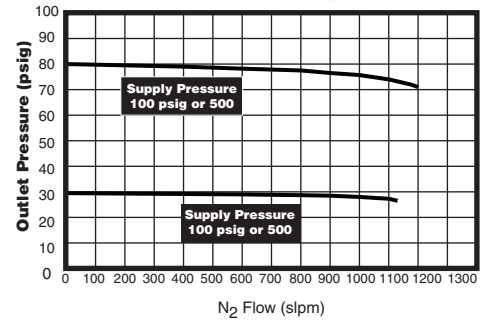

Porting Configurations

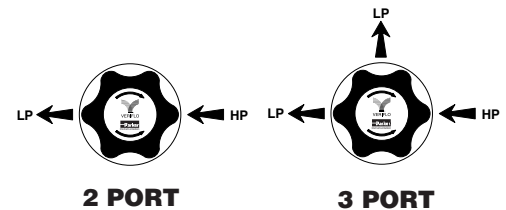

Ordering Information

SPR860 W 3P V3 FS8 MMF V PM

BASIC SERIES

SPR860 = 0 - 30 psig
 SPR861 = 0 - 100 psig
 SPR862 = 0 - 150 psig

MATERIALS

W = Welded 316L Stainless Steel

PORTING

2P = 2 Ports
 3P = 3 Ports

REGULATOR OUTLET GAUGE

V3 = -30 in Hg - 0 - 30 psig
 V1 = -30 in Hg - 0 - 100 psig
 VX = -30 in Hg - 0 - 150 psig
 V2 = -30 in Hg - 0 - 200 psig
 2 = 0 - 200 psig
 X = No Gauge

OPTIONAL FEATURES

PM = Panel Mount

SEAL MATERIAL

V = Viton® (500 psig max)
 K = Kalrez® (200 psig max)

PORT CONFIGURATIONS (Face Seal Only)

M = Male
 F = Female
 I = Internal Female FS (1/4" Gauge Port Only)

PORT STYLE

FS = 1/4" Face Seal
 FS8 = 1/2" Face Seal
 FS12 = 3/4" Face Seal

Kalrez® and Teflon® are registered trademarks of DuPont Company.
 Viton® is a registered trademark of DuPont Dow Elastomers.





Parker Hannifin Corporation's Veriflo Division presents the BFR5K Bulk Gas Series regulator. The BFR5K was created in response to the need for a small, high flow, high performance regulator for semiconductor processing.

This state-of-the-art device builds on the knowledge gained in fabrication of the Veriflo SQ regulator line to provide the cleanest operating gas components available in the world.

The BFR5K provides a stable outlet pressure over a wide variety of conditions with flow rates as high as 5000 slpm.



The unique balanced poppet design allows the regulator to maintain the outlet pressure setting regardless of changes in the upstream pressure.

features

- ▶ Standard 316L Stainless Steel Poppet and 321 Stainless Steel Bellows.
- ▶ High flow capacity with minimal pressure drop.
- ▶ Balanced poppet provides for minimal supply pressure effect.
- ▶ Tied diaphragm to poppet for added safety.
- ▶ Hurricane cleaning for "near absolute" contamination control.

Capable of operating at a wide range of flows from 100 up to 10,000 slpm.

Design and materials of construction ensure compatibility with semiconductor bulk gases.

No wetted spring.

materials of construction

Wetted

Body "VeriClean", Veriflo's high purity type 316L VAR Stainless Steel™
 Seat PCTFE
 Bellows:
 Inner Inconel® 718
 Outer 321 Stainless Steel
 Poppet & Trim "VeriClean", Veriflo's high purity type 316L VAR Stainless Steel

Non-wetted

Cap. Nickel Plated Brass

operating conditions

Maximum inlet pressure 500 psig
 Outlet pressure 0-200 psig
 Temperature -40°F to 150°F (-40°C to 66°C)

functional performance

Flow Capacity C_v 4.5
 (SEMI Flow Coefficient F-32)

Design Leak Rate:

Across Seat 5×10^{-6} scc/sec He
 Inboard 2×10^{-10} scc/sec He
 Outboard 1×10^{-9} scc/sec He

standard connections

See chart on reverse side

surface finishes

Standard Ra 10 micro inch
 (.25 micro meter) or less
 Optional Ra EV=5 micro inch
 (.13 micro meter) or less

internal volume

71 cc without connections

approximate weight

Dome Loaded 5.7 lbs (2.6 kg)
 Manual 7.7 lbs (3.5 kg)
 (with 1.00" Tube Stubs)

BFR5K Series

Dimensional Drawing

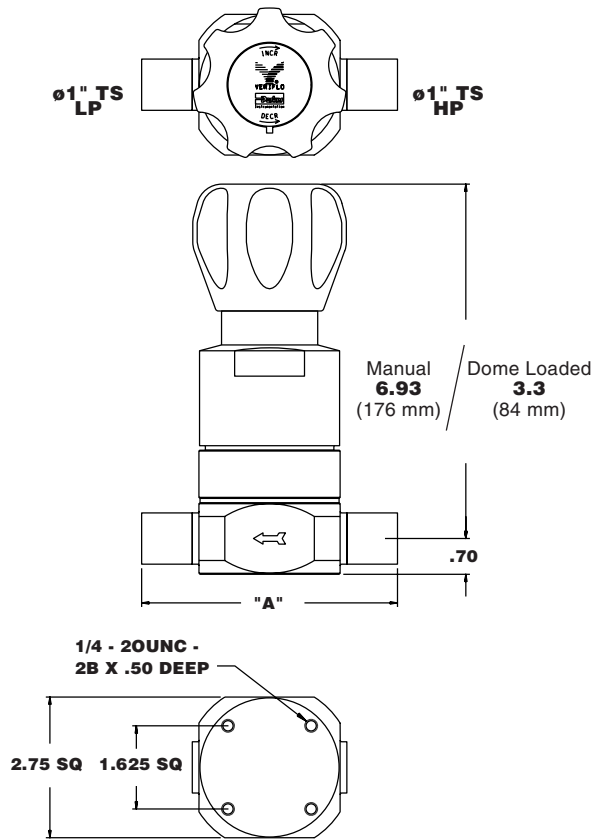

Flow Curves

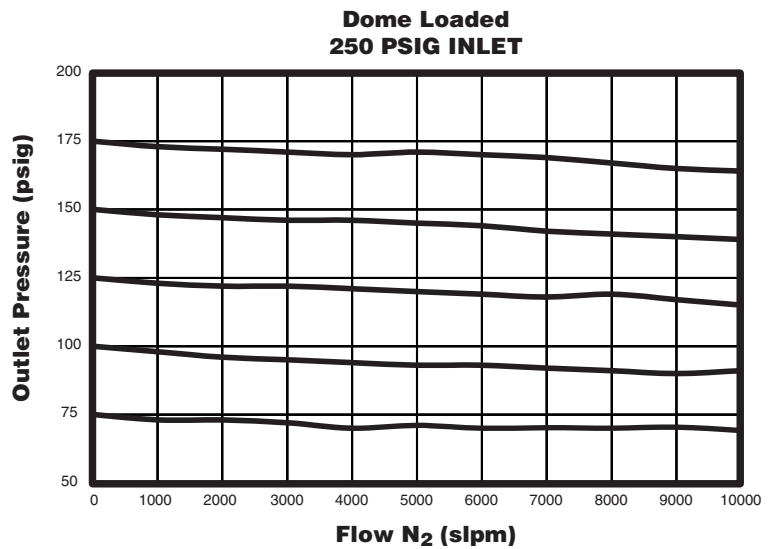

End to End Dimension Chart			
Tubing			
	3/4" Tube	1" Tube	1.5" Tube
"A" inches	5.0	5.0	10.5
"A" mm	127.0	127.0	266.7
Fitting			
	3/4" Face Seals	1" Face Seals	
"A" inches	6	6.5	
"A" mm	152.4	165.1	

Ordering Information

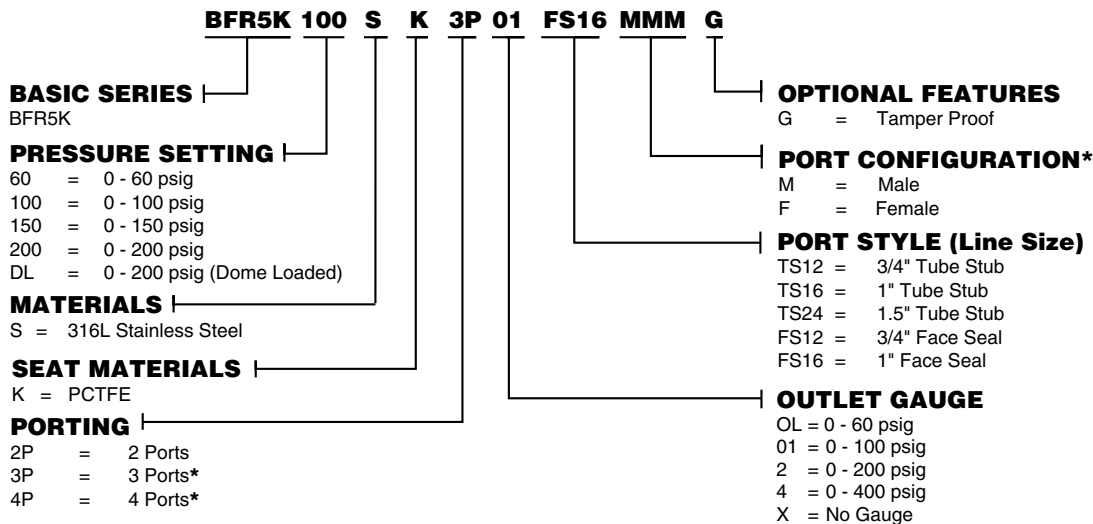

* Gauge port is standard 1/4" Face Seal Male only.

Inconel® is a registered trademark on Inco Alloys International.
PEEK™ is a trademark of Victrex plc.



Applications

The SQServo pressure regulators have been developed for two basic groups of applications:

- Delivery of very high flow rates of gas.
- Precise control of a gas delivery pressure under changing flow conditions.

The SQServo Pressure Regulators (SQServo140E and the SQServo420E) require an external source of Nitrogen or CDA to operate at a minimum of 20 psig greater than the maximum outlet pressure. As a safety measure, if an interruption of the control gas supply occurs, the gas delivery from the SQServo will be shut off automatically.

A continuous bleed of dome pressure of about .5 SLPM will vent from the Servo Control Mechanism and is used to improve the resolution sensitivity of the outlet pressure regulation.

Operational Information

The pressure regulator incorporates two functional components integrated into a single unit. The smaller component is a pressure sensor and controller. It senses the outlet pressure, compares it to a mechanical pressure setting, and generates a control signal as a function of the difference between the actual outlet pressure and the pressure setting. It does not obstruct the flow through the device.

The larger component is a pneumatically "dome loaded" SQ (high flow) pressure regulator. It receives the pneumatic signal sent by the controller and functions to create an outlet pressure equal to the pressure setting. The two components work together to minimize the difference between the pressure setting and the actual outlet pressure independent of flow. Through the comparison of the pressures and the "amplification" of the servo mechanism, a small deviation from the pressure setting (< 1 psig) can create a large change in the position of the SQServo valve-seat assembly, to the point of effectively using the entire C_v capability of the pressure regulator.

Two sizes of SQServo regulators are offered as indicated in the C_v Chart below:

SQServo C_v Chart		
Model	C_v	Max Inlet
SQServo140E	.25	1250 psig (86 barg)
SQServo420E	1.2	250 psig (17 barg)

Dimensional Drawing

All dimensions are reference and nominal.

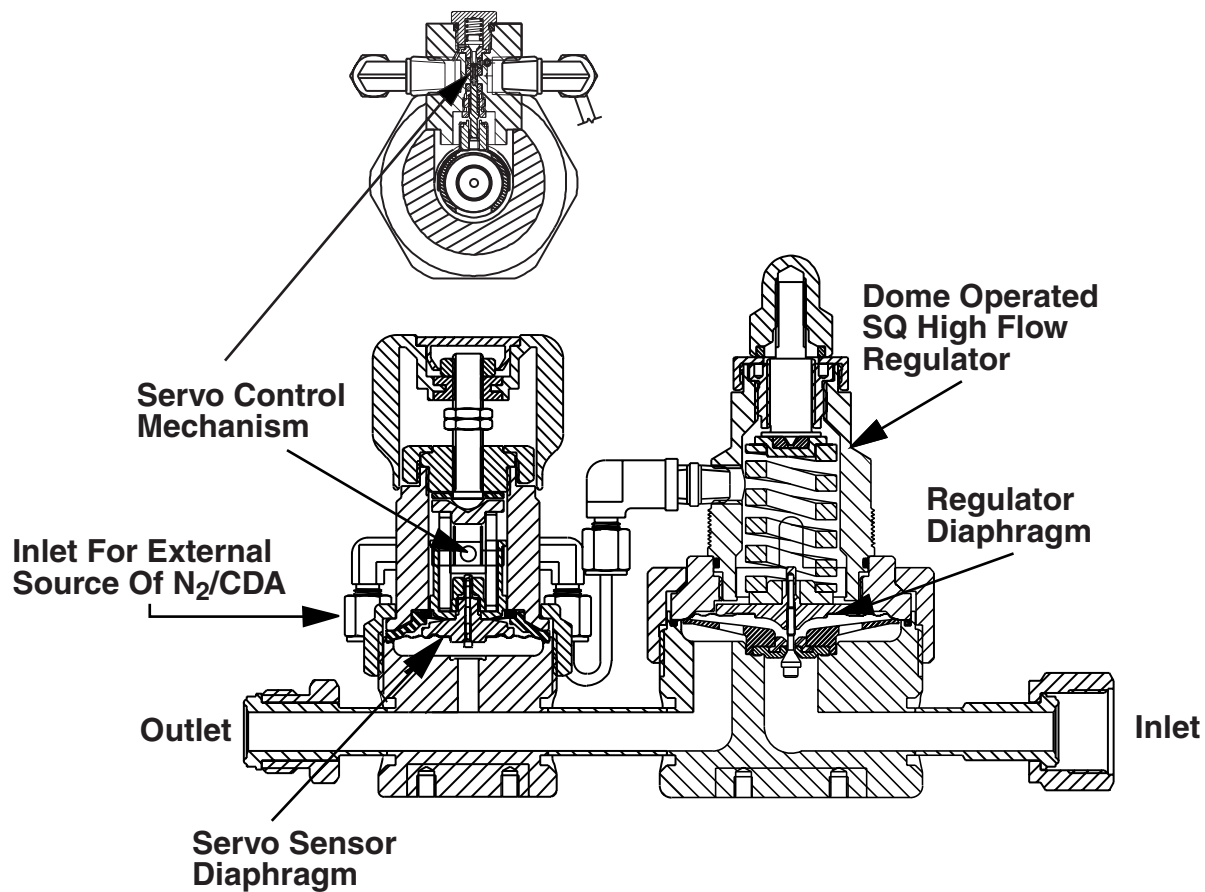

Flow Curves

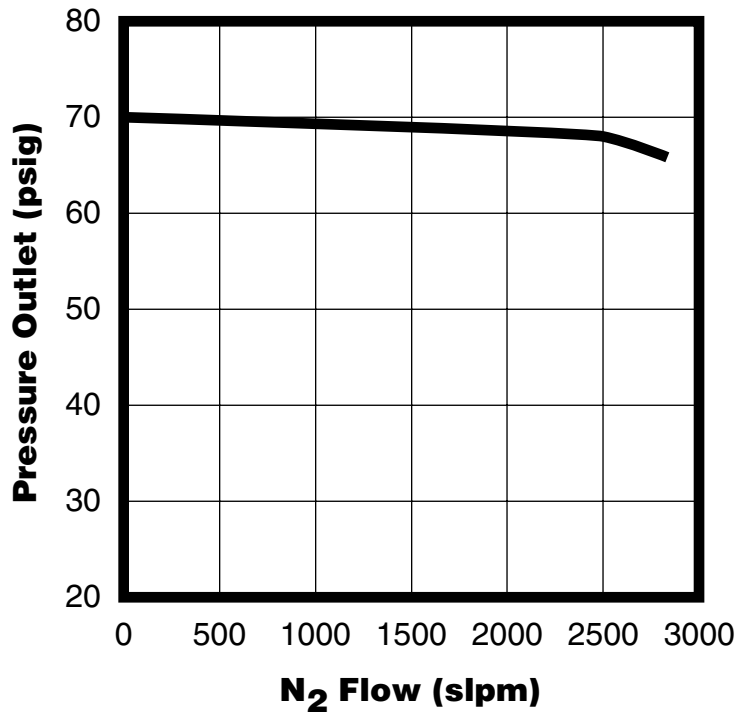

Ordering Information

SQSERVO140E 30 3P V1 FS8 FM SS

BASIC SERIES

SQSERVO140E
SQSERVO420E

BASIC MODEL

30 = 0 - 30 psig
50 = 0 - 50 psig
100 = 0 - 100 psig

PORTING

2P = 2 Ports
3P = 3 Ports

OUTLET GAUGE

V3 = -30 in. Hg- 0 - 30 psig
L = -30 in. Hg- 0 - 60 psig
V1 = -30 in. Hg- 0 - 100 psig
X = No gauge

OPTIONAL FEATURES

SS = Stainless Steel Internals†
TH = Hastelloy C-22® Trim
(Compression Member)
VESP = Vespel® Seat *
xxxx = Preset**

PORT CONFIGURATION

M = Male
F = Female

PORT STYLE

FS8 = 1/2" Face Seal
FS12 = 3/4" Face Seal
TS6 = 3/8" Tube Stub
TS8 = 1/2" Tube Stub
TS12 = 3/4" Tube Stub

* Recommended for Nitrous Oxide (N₂O) Service

** Special 4-digit number will be issued by factory to indicate customer specific pressure setting

† Recommended for Carbon Monoxide (CO) or Nickel Carbonyl Ni(CO)₄ Service

Hastelloy C-22® is a registered trademark of Haynes International, Inc.

Kel-F 81® is a registered trademark of 3M Company.

Vespel® is a registered trademark of DuPont Company.



Parker Hannifin Corporation
 6035 Parkland Blvd.
 Cleveland, Ohio 44124-4141
 Telephone: (216) 896-3000
 Fax: (216) 896-4000
 www.parker.com

Parker Hannifin Corporation

About Parker Hannifin Corporation

Parker Hannifin is a leading global motion-control company dedicated to delivering premier customer service. A Fortune 500 corporation listed on the New York Stock Exchange (PH), our components and systems comprise over 1,400 product lines that control motion in some 1,000 industrial and aerospace markets. Parker is the only manufacturer to offer its customers a choice of hydraulic, pneumatic, and electromechanical motion-control solutions. Our Company has the largest distribution network in its field, with over 7,500 distributors serving nearly 400,000 customers worldwide.

Parker's Charter

To be a leading worldwide manufacturer of components and systems for the builders and users of durable goods. More specifically, we will design, market and manufacture products controlling motion, flow and pressure. We will achieve profitable growth through premier customer service.

Product Information

North American customers seeking product information, the location of a nearby distributor, or repair services will receive prompt attention by calling the Parker Product Information Center at our toll-free number: 1-800-C-PARKER (1-800-272-7537). In Europe, call 00800-C-PARKER-H (00800-2727-5374).

The Aerospace Group is a leader in the development, design, manufacture and servicing of control systems and components for aerospace and related high-technology markets, while achieving growth through premier customer service.

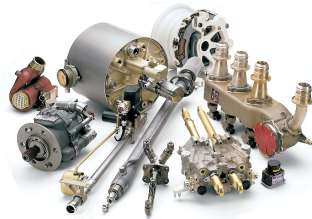

The Climate & Industrial Controls Group designs, manufactures and markets system-control and fluid-handling components and systems to refrigeration, air-conditioning and industrial customers worldwide.



The Fluid Connectors Group designs, manufactures and markets rigid and flexible connectors, and associated products used in pneumatic and fluid systems.



The Seal Group designs, manufactures and distributes industrial and commercial sealing devices and related products by providing superior quality and total customer satisfaction.



The Hydraulics Group designs, produces and markets a full spectrum of hydraulic components and systems to builders and users of industrial and mobile machinery and equipment.



The Filtration Group designs, manufactures and markets quality filtration and clarification products, providing customers with the best value, quality, technical support, and global availability.



The Automation Group is a leading supplier of pneumatic and electromechanical components and systems to automation customers worldwide.



The Instrumentation Group is a global leader in the design, manufacture and distribution of high-quality critical flow components for worldwide process instrumentation, ultra-high-purity, medical and analytical applications.





Parker Hannifin Corporation
Veriflo Division
250 Canal Boulevard
Richmond, CA 94804-0034
Telephone 510.235.9590
Fax 510.232.7396
<http://www.veriflo.com>

Catalog: 4508
LitPN: 25000182
Revision: A • 10/03

