

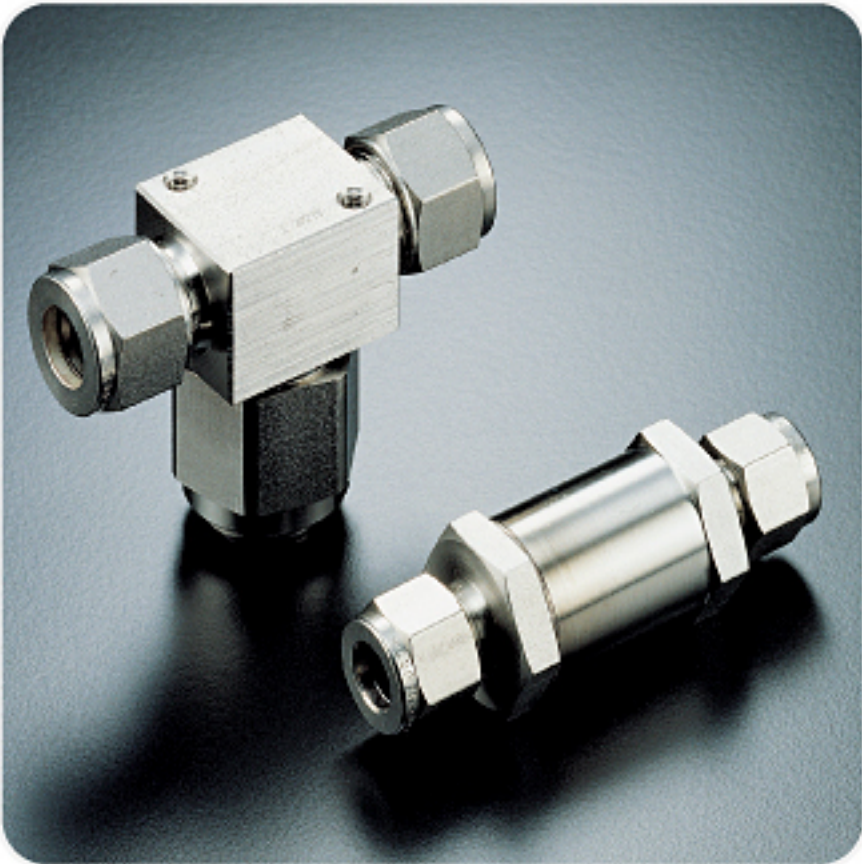

THE POWER OF RELIABILITY
www.dklok.com



Filters



Filters for System Purity

V73 Series In-line Filters



V76 Series Tee Filters



Features

- Traps fine contamination to maintain system purity
- Gas and liquid filtration
- Standard micron filtering ranges : 0.5, 2, 7, 15, 60 and 90 microns
- Replaceable SS316 sintered elements
- SS316 and Brass body construction
- Choice of reliable Dk-Lok, NPT & ISO pipe end connections
- Heat Code Traceability

V73 Series In-line Filters

- In-line filters are applicable where space is limited and elements don't have to be replaced often.
- Compact in-line design with large filtration area
- Maximum working pressure 3000 psig @100°F (206 bar @38°C)

V76 Series Tee Filters

- Filter Element replaceable with the valve in-line.
- Safety union bonnet design for high pressure rating
- Optional Bypass for sampling or purging of process fluid.
- Maximum working pressure 6000 psig @100°F (413 bar @38°C)

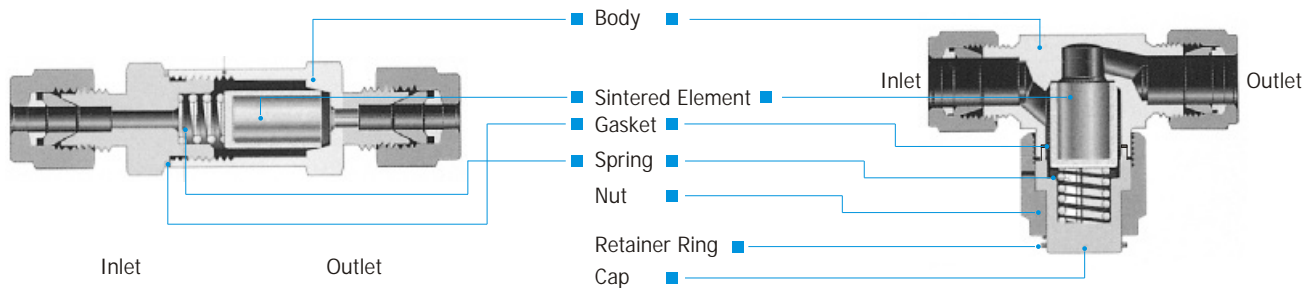

Materials of Construction

Component	V73 Series		V76 Series	
	Grade/ASTM Specification			
Body	SS316 / A276	Brass / B16	SS316 / A276	Brass / B16
Nut	-	-	SS316 / A276	Brass / B16
Cap	-	-	SS316 / A276	Brass / B16
Retainer Ring	-	-	Stainless Steel	
Sintered Element	SS316			
Spring	SS302			
Gasket	SS316 / A240 silver plated			

Wetted components are listed in blue.

Filtration Definitions

- **Filter Element :**
The component within the filter which traps media contamination.
- **Filtration Area :**
The actual surface area of the filter element available to trap contamination.
- **Micron :**
A unit of measure to describe the mean pore diameter of the filter element or the mean particle diameter of media contamination.
One micron = 0.001mm or 0.00004 inch

Sintered Elements Technical Information

- Stainless steel 316 sintered
- High heat resistance and thermal stability up to 1500°F (815°C).
- High permeability with low-pressure drop.
- Shape-stability with self-supporting structural elements
- Suitable for compression, vibration, and high impulse pressures.
- Precise filtration because pore size and distribution are exact and uniform.
- Chemical resistance against acids and caustic solutions in various ranges of pH.

Element Designator	Nominal Pore Size, µm	Pore Size Range, µm	Element Porosity	Cv Factor	Max. Pressure Differential Across Clean Filters at 70°F (21°C)
05	0.5	0.5 - 2	17%	0.046	1160 psig (80.0 bar)
2	2	1 - 4	22%	0.056	
7	7	5 - 10	27%	0.12	
15	15	11 - 25	36%	0.13	
60	60	50 - 75	44%	0.38	
90	90	75 - 110	45%	0.50	

Element Replacement

- The sintered elements don't permit the contaminants in the gas and liquid to pass through the elements when they are bigger than the pore size of micron.
- Contaminants are trapped by element pores and it results in pressure buildup.
- Contamination comes earlier when flow volume is high and media is not clean.
- The filtering elements need to be replaced for minimum pressure drop as well as system purity.

Note: Clean filter valve components whenever the element is replaced.

V73 Series In-line Filters

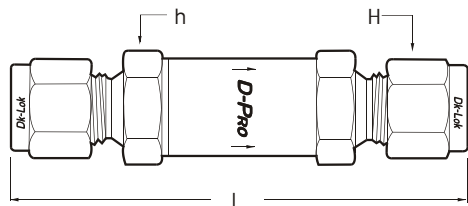

Ordering Information and Dimensions

Basic Ordering Number	End Connections Inlet and Outlet	Orifice inch (mm)	Dimensions, mm (in.)		
			L	H	h
V73A-	D-2T- 1/8 in. DK-LOK	0.09 (2.4)	59.7 (2.35)	7/16	9/16
	F-2N- 1/8 in. Female NPT		54.9 (2.16)	-	
	D-3M- 3mm DK-LOK		60.5 (2.38)	12mm	
V73B-	D-4T- 1/4 in. DK-LOK	0.19 (4.7)	74.9 (2.95)	9/16	3/4
	M-2N- 1/4 in. Male NPT		68.3 (2.69)	-	
	F-4N- 1/4 in. Female NPT		72.9 (2.87)	-	
	D-6M- 6mm DK-LOK		75.2 (2.96)	14mm	
V73C-	M-8N- 1/2 in. Male NPT	0.28 (7.1)	81.3 (3.20)	1-1/16	1
	D-6T- 3/8 in. DK-LOK		81.5 (3.21)	-	
V73D-	D-8T- 1/2 in. DK-LOK	0.41 (10.3)	88.6 (3.49)	7/8	1

All dimensions shown are for reference only and are subject to change. Dimensions with Dk-Lok nuts are in finger-tight position.

Flow Capacities

Filter Series	Nominal Pore Micron	P		
		20 psi	60 psi	120 psi
Water GPM @70°F (21°C)				
73A Series	05	0.01	0.44	0.13
	2	0.11	0.26	0.44
	7	0.14	0.33	0.53
	15	0.17	0.39	0.64
	60	0.21	0.55	0.77
	90	0.28	0.55	0.66
73B Series	05	0.06	0.19	0.32
	2	0.34	0.94	1.42
	7	0.57	1.42	2.19
	15	0.71	1.42	2.30
	60	1.27	3.61	5.04
	90	1.70	4.60	6.68
73C Series	05	0.13	0.44	0.83
	2	0.37	1.20	1.75
	7	0.91	2.41	3.83
73D Series	15	1.19	2.85	4.49
	60	2.83	7.34	10.95
	90	3.25	8.32	12.05

Technical Information

Filter Series	Pressure Rating @100°F (38°C)		Temperature Rating °F (°C)		Filtration Area with Sintered Element inch² (mm²)
	Body Material	SS316	Brass	SS316	
V73A	3000 (206)	3000 (206)	-20 to 900 (-28 to 482)	-20 to 300 (-28 to 148)	0.55 (350)
V73B					1.30 (830)
V73C, V73D	2500 (172)	2000 (137)			2.0 (1280)

V76 Series Tee Filters

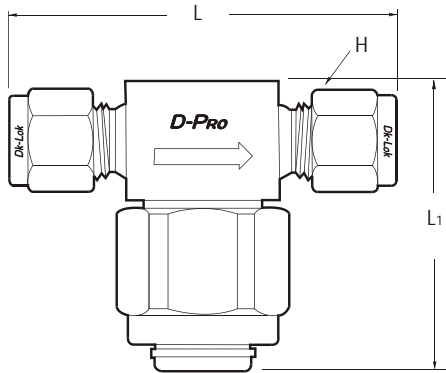

■ Top mounting

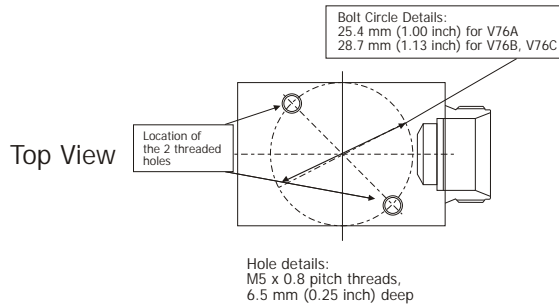

Ordering Information and Dimensions

Basic Ordering Number	End Connections Inlet & Outlet	Orifice inch (in.)	Dimensions, mm (in.)		
			L	L1	H
V76A	F-2N-	1/8 in. Female NPT	50.8 (2.00)	47.5 (1.87)	-
	D-2T-	1/8 in. DK-LOK	57.7 (2.27)		7/16
	D-4T-	1/4 in. DK-LOK	62.7 (2.47)		9/16
	M-4N-	1/4 in. Male NPT	54.1 (2.13)		-
	F-4N-	1/4 in. Female NPT	54.1 (2.13)		-
	D-6M-	6mm DK-LOK	62.5 (2.46)		14mm
V76B	D-6T-	3/8 in. DK-LOK	72.1 (2.84)	56 (2.20)	11/16
	D-8M-	8mm DK-LOK	72.1 (2.84)	16mm	
V76C	M-6N-	3/8 in. Male NPT	60.5 (2.38)	56 (2.20)	-
	D-10M-	10mm DK-LOK	72.6 (2.86)		19mm
	D-12M-	12mm DK-LOK	77.2 (3.04)		22mm
	D-8T-	1/2 in. DK-LOK	77.2 (3.04)		7/8
	M-8N-	1/2 in. Male NPT	69.9 (2.75)		-

All dimensions shown are for reference only and are subject to change. Dimensions with Dk-Lok® nuts are in finger-tight position.

Technical Information

Filter Series	Pressure Rating @100°F (38°C) psig (bar)		Temperature Rating °F (°C)		Filtration Area with Sintered Element inch² (mm²)
	SS316	Brass	SS316	Brass	
V76A, V76B	6000 (413)	2000 (137)	-20 to 900 (-28 to 482)	-20 to 300 (-28 to 148)	1.3 (830)
V76C	6000 (413)	2000 (137)			2.0 (1280)

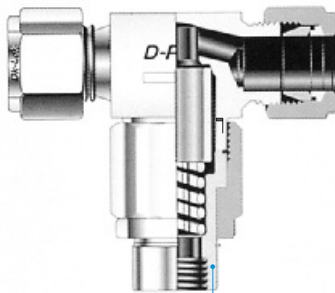

By-pass port
By-pass port of female 1/8 in. or 1/4 in. NPT is available for sampling and purging of process fluid.
To use, replace the cap on Tee filter with the by-pass port.

Operation
Keep the cap downwards to prevent contaminants from entering the system during element replacement.

Filter Series	Nom. Pore Micron	P		
		20 psi	60 psi	120 psi
		Water GPM @ 70°F (21°C)		
V76A-F-2N V76A-D-2T	05	0.06	0.19	0.32
	2	0.11	0.26	0.44
	7	0.14	0.33	0.53
	15	0.17	0.39	0.64
	60	0.21	0.55	0.77
V76A-D-4T V76A-M-4N V76A-F-4N	90	0.28	0.55	0.66
	05	0.06	0.19	0.32
	2	0.34	0.94	1.42
	7	0.57	1.42	2.19
	15	0.71	1.42	2.30
V76A-D-6M V76A-D-6T V76B Series V76C Series	60	1.13	2.96	4.27
	90	1.56	3.72	5.37
	05	0.13	0.44	0.83
	2	0.37	1.20	1.75
	7	0.91	2.41	3.83
	15	1.19	2.85	4.49
	60	2.12	5.26	7.34
90	2.40	6.02	8.33	

Ordering information

Select desired basic ordering number, element designator, option and body material listed below.

V76A-D-4T -7
V76B-D-6T

-NE

-BF2N

-S

-B

Sintered Element		Filter with no element	By-pass	Body Material
Element Designator	Nominal Micron	<ul style="list-style-type: none"> ●NE: Filter with no element Note: NE option is applicable to V76 series Tee filter only.	<ul style="list-style-type: none"> ●Nil: No By-pass option ●BF2N: 1/8 in. Female NPT ●BF4N: 1/4 in. Female NPT 	<ul style="list-style-type: none"> ● S : SS316 ● B : Brass
05	0.5			
2	2			
7	7			
15	15			
60	60			
90	90			



Field Assembly Kit

Sintered Element Kits

To order, select desired kit basic ordering number and element designator. Example: FE73A-05..

Element Kit Basic Ordering Number	Kit applicable Filter Series	Element Designator	Nominal Pore Size, µm	Pore Size Range, µm
FE73A-	V73A	05	0.5	05 - 2
		2	2	1 - 4
FE73B-	V73B V76A	7	7	5 - 10
		15	15	11 - 25
FE73C-	V73C, V73D V76B, V76C	60	60	50 - 75
		90	90	75 - 110

Gasket and Spring Kits

To order, select desired gasket or spring kit ordering number.

Filter Series	Gasket Kit Ordering Number	Spring Kit Ordering Number	Kit applicable Filter Series
V73 Stainless Brass	9WSH-73A-S	9SPR-73A-2	V73A
	9WSH-73B-S	9SPR-73B-2	V73B
	9WSH-73C-S	9SPR-73C-S	V73C
	9WSH-73D-S	9SPR-73D-2	V73D
V76 Stainless Brass	9WSH-76A-S	9SPR-76A-2	V76A
	9WSH-76B-S	9SPR-76B-2	V76B
	9WSH-76C-S	9SPR-76C-2	V76C

We reserve the right to change specifications stated in this catalog for our continuing program of improvement.

Safe Filter Selection

The Selection of a Filter for any application or system design must be considered to ensure safe performance. Filter function, Filter rating, material compatibility, proper installation, operation and maintenance remain the sole responsibility of the system designer and the user. Dk Tech accepts no liability for any improper selection, installation, operation or maintenance.



DK TECH Trademarks

D-Pro Valves **Dk-Lok** Tube Fittings **Green** Pipe & Weld Fittings

Mailing Address
826, Naesam-Ri, Juchon-Myeon, Gimhae-City,
Gyeong Nam, Korea 621-841

DK TECK contact information | For International customers
Tel. (82) 55-338-0114 | Tel. (82) 55-338-0031/2
Fax (82) 55-338-6745 | Fax (82) 55-338-6746
E-mail: sales@dklok.com | E-mail: dklok@dklok.com